

# FÉDÉRATION INTERNATIONALE DU SPORT AUTOMOBILE

ONS Oberste Nationale Sportkommission für den Automobilsport in Deutschland GmbH

Homologation Nr.

**B - 207**



Gruppe **A/B**  
Group

esblatt nach Anhang J des Internationalen Automobil-Sportgesetzes

Homologation form in accordance with appendix J of the international sporting code

Homologation gültig ab  
Homologation valid as from

1. -1. MAI 1982

in Gruppe B  
in group

Foto A  
Photo A



Foto B  
Photo B



## 1. Definitionen Definitions

101. Hersteller Dr. Ing. h. c. F. Porsche AG  
Manufacturer

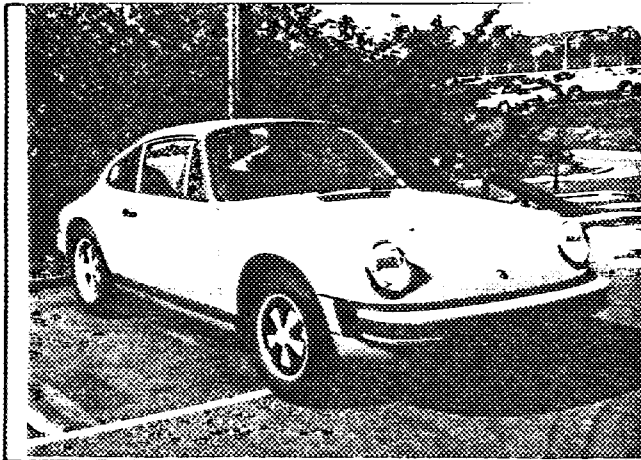
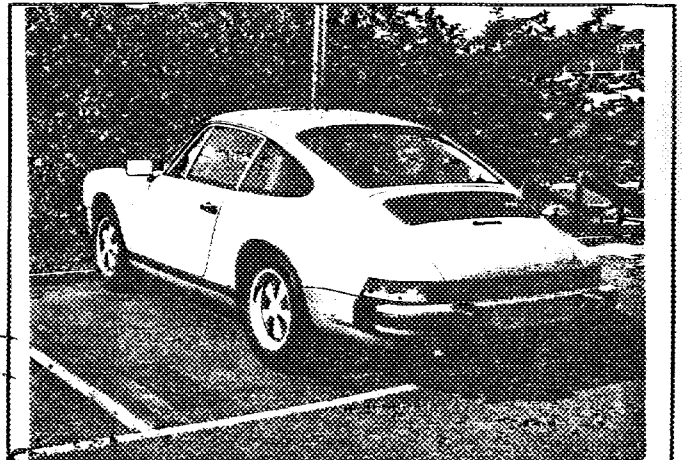
102. Handelsbezeichnung — Typ und Modell 911 SC  
Commercial name(s) — Type and model

103. Gesamthubraum 2687 ccm  
Cylinder capacity

104. Art der Konstruktion  getrennt, Material des Chassis  
Type of car construction Separate material of chassis

selbsttragend, Material der Karosserie Stahl / steel  
Unitary construction

105. Anzahl der Volumina 2  
Number of volumes

106. Anzahl der Sitzplätze 2+2  
Number of places

Unterschrift und Stempel  
der Nationalen Sportkommission  
Signature and stamp  
of national sport authority



Unterschrift und Stempel  
der FISA  
Signature and stamp  
of FISA

**2. Abmessungen — Gewichte**  
Dimensions — weights

202. Länge über alles 4291 mm ± 1 %  
Overall length
203. Breite über alles 1652 mm ± 1 % Meßpunkt über Hinterachse  
Overall width Where measured above rear axle
204. Karosseriebreite: 1610 mm ± 1 %  
Width of bodywork: a) Vorderradmitte 1610 mm ± 1 %  
At front axle
- b) Hinterradmitte 1652 mm ± 1 %  
At rear axle
206. Radstand: a) Rechts 2272 mm ± 1 % b) Links 2272 mm ± 1 %  
Wheelbase: Right Left
209. Überhang: a) Vorne 932 mm ± 1 % b) Hinten 1087 mm ± 1 %  
Overhang: Front Rear
210. Entfernung „G“ (Lenkrad-hintere Trennwand) 1380 mm ± 1 %  
Distance „G“ (steering wheel — rear bulkhead)

**3. Motor (Für Kreiskolbenmotor siehe Artikel 335 auf Nachtragsblatt)**  
Engine (In case of rotative engine, see Article 335 on complementary form)

301. Einbauort und Lage des Motors hinten / rear längs 0° / longitudinal 0°  
Location and position of the engine
303. Arbeitsverfahren Viertakt-Otto-Motor / four-stroke Otto engine  
Cycle
304. Aufladung ja / nein; Typ \_\_\_\_\_  
Supercharging yes/no; Type \_\_\_\_\_  
(Bei Aufladung siehe auch Artikel 334 auf Nachtragsblatt)  
(In case of supercharging see also Article 334 on complementary form)
305. Anzahl und Anordnung der Zylinder Sechszylinder-Boxer / six cylinder Boxer engine  
Number and layout of the cylinders
306. Kühlsystem luftgekühlt / air-cooled  
Cooling system

307. Hubraum: a) Pro Zylinder 448 ccm b) Gesamt 2687 ccm  
Cylinder capacity a) Unitary Total
- c) Maximal zulässiger Hubraum\* 2721,76 ccm  
ci) Maximum total allowed\*

\* (Diese Angabe gilt nicht für Gruppe N)  
\* (This indication is not to be considered in Group N)



Marke Porsche  
Make

Modell 911 SC  
Model

Homologation Nr. B-207  
Homologation Nr.

312. Material des Zylinderblocks Leichtmetall / light alloy  
Cylinder block material

313. Laufbuchsen: a) ja / ~~nein~~  ja / ~~no~~  yes / ~~no~~   
Sleeves: yes / no  
c) Typ Einzelzylinder /  
Type single piece cylinder

314. Bohrung 90 mm  
Bore

315. Maximal zulässige Bohrung 90,6 mm  
Maximum bore allowed  
(Diese Angabe gilt nicht für Gruppe N)  
(This indication is not be considered in Group N)

316. Hub 70,4 mm  
Stroke

318. Pleuel: a) Material Stahl / steel b) Art des Pleueifüßes geteilt / divided  
Connecting rod: a) Material Big end type

c) Innerer Durchmesser des Pleueifüßes (ohne Lager) 56 mm  $\pm 1\%$   
Interior diameter of the big end (without bearings)

d) Länge zwischen den Achsen 127,8 mm ( $\pm 0,1$  mm) e) Mindestgewicht 600 g  
Length between the axes Minimum weight

319. Kurbelwelle: a) Herstellungsart einteilig / single piece  
Crankshaft: type of manufacture

b) Material Stahl / steel  
Material

c)  gegossen  geschmiedet d) Anzahl der Kurbelwellen-Hauptlager 8  
moulded stamped Number of bearings

e) Art der Kurbelwellen-Hauptlager Gleitlager / slide bearing  
Type of bearings

f) Durchmesser der Kurbelwellen-Hauptlager 57 mm  $\pm 0,2\%$   
Diameter of bearings

g) Material der Lagerdeckel -----  
Bearing caps material

h) Mindestgewicht der Kurbelwelle (allein) 11800 g  
Minimum weight of the bare crankshaft

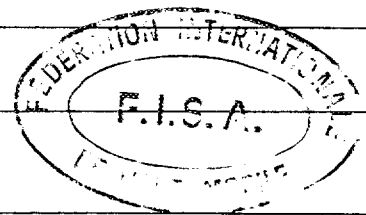

320. Schwungrad: a) Material Stahl / steel  
Flywheel: Material

b) Mindestgewicht mit Anlaßzahnkranz 3600 g  
Minimum weight of the flywheel with starter ring

321. Zylinderkopf: a) Anzahl der Zylinderköpfe 6 b) Material Leichtmetall / light alloy  
Cylinderhead: Number of cylinderheads Material

323. Kraftstoffzufuhr durch Vergaser: a) Anzahl der Vergaser -----  
Fuel feed by carburetors: Number of carburetors

b) Typ \*\* \* \*  
Type  
\* \* \* \* \*  
\* \* \* \* \*  
\* \* \* \* \*  
\* \* \* \* \*  
\* \* \* \* \*

Marke Porsche  
Make

Modell 911 SC  
Model

Homologation Nr. B-207  
Homologation Nr.

- d) Anzahl der Gemischdurchlässe je Vergaser \_\_\_\_\_  
Number of mixture passages per carburettor
- e) Maximaler Durchmesser der Gemischöffnung am Vergaserausgang \_\_\_\_\_ mm  
Maximum diameter of the flange hole of the carburettor exit port
- f) Durchmesser des Lufttrichters am engsten Punkt \_\_\_\_\_ mm  
Diameter of the venturi at the narrowest point

324. Kraftstoffzufuhr durch Einspritzung  
Fuel feed by injection:

a) Hersteller Bosch  
Manufacturer

b) Modell des Einspritzsystems Sechs-Stempel-Doppel-Reihenpumpe / Injection pump  
Model of injection system

c) Art der Kraftstoffdosierung  mechanisch  elektronisch  hydraulisch  
Kind of fuel measurement mechanical electronic hydraulic

c1) Kolbenpumpe  ja /  nein  ja /  nein  
Piston pump yes/no yes/no

c3) Luftmassenmessung  ja /  nein  ja /  nein  
Measurement of air mass yes/no yes/no

c5) Luftdruckmessung  ja /  nein Weicher Druck wird zur Messung herangezogen? 1,0 bar  
Measurement of air pressure yes/no Which pressure is taken for measurement?

d) Abmessungen der Drosselklappe(n) oder der/des Schieber(s) 38 mm  
Effective dimensions of measure position in the throttle area

e) Anzahl der effektiven Kraftstoffauslässe 6  
Number of effective fuel outlets

f) Lage der Einspritzventile  Saugrohr  Zylinderkopf  
Position of injection valves Inlet manifold Cylinderhead

g) Teile des Einspritzsystems, die zur Kraftstoffdosierung dienen: Einspritzpumpe / Fuel injection pump  
Statement of fuel measuring parts of injection system



325. Nockenwelle: a) Anzahl 2  
Camshaft Number

b) Lage OHC  
Location

c) Art des Antriebs Ketten / by chain d) Anzahl der Lager pro Nockenwelle 3  
Driving system Number of bearings for each shaft

f) Art der Ventilbetätigung durch Kipphebel / by toggle switch  
Type of valve operation

326. Steuerung: e) Maximaler Ventilhub 11,5 mm Einlaß 10,1 mm  
Timing Maximum valve lift Inlet Exhaust

Mit einem Spiel von 0,1 mm 0,1 mm  
With clearance

327. Einlaß: a) Material des Ansaugkrümmers Leichtmetall und Kunststoff / light alloy and plastic  
Inlet Material of the manifold

b) Anzahl der Ansaugkrümmerelemente 2 c) Anzahl der Ventile pro Zylinder 1  
Number of manifold elements Number of valves per cylinder

d) Maximaler Durchmesser der Ventile 46 mm e) Durchmesser des Ventilschafts 9,0 mm  
Maximum diameter of the valves Diameter of the valve stem

f) Länge des Ventils 110,1 ± 0,25 mm g) Art der Ventilfeeder Schraubenfeder / coil spring  
Length of the valve Type of valve springs



Marke Porsche Modell 911 SC Homologation Nr. B-207  
Make Model Homologation Nr.

328. Auslaß: a) Material des Auslaßkrümmers Stahl / steel  
Exhaust: Material of the manifold.  
b) Anzahl der Auslaßkrümmerelemente 2 d) Anzahl der Ventile pro Zylinder 1  
Number of manifold elements Number of valves per cylinder  
e) Maximaler Durchmesser der Ventile 40 mm f) Durchmesser des Ventilschafts 9 mm  
Maximum diameter of the valves Diameter of the valve stem  
g) Länge des Ventils 108,4 ± 0,25 mm h) Art der Ventillfeder Schraubenfeder / coil  
Length of the valve Type of valve springs spring

330. Zündanlage: a) Art BHKZ Batterie / battery  
Ignition system: Type  
b) Anzahl der Kerzen pro Zylinder 1 c) Anzahl der Verteiler 1  
Number of plugs per cylinder Number of distributors

333. Schmiersystem: a) Art Trockensumpf /  
Lubrication system: Type dry sump b) Anzahl der Ölpumpen 1  
Number of oil pumps

#### 4. Kraftstoffanlage Fuel circuit

401. Tank: a) Anzahl 1 b) Lage vorn / front  
Fuel tank: Number Location  
c) Material Stahl d) Maximaler Inhalt 80 Liter  
Material steel Maximum capacity litre

#### 5. Elektrische Ausrüstung Electrical equipment

501. Batterie(n): a) Anzahl 1  
Battery(ies): Number

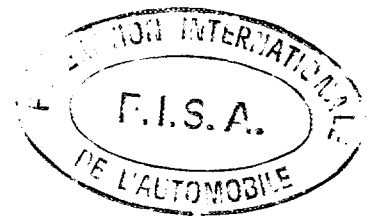

#### 6. Kraftübertragung Drive

601. Antriebsräder  vorn  hinten  
driving wheels: front rear

602. Kupplung: b) Art der Betätigung durch Kabel / by cable  
Clutch: Drive system  
c) Anzahl der Scheiben 1  
Number of plates

603. Getriebe: a) Lage hinten vor Motor / in front of the engine (rear)  
 Gear-box: Location

b) Manuelles Getriebe, Marke Porsche c) Automatisches Getriebe, Marke \_\_\_\_\_  
 „Manual“ make „Automatic“ make

d) Anordnung des Gangschalthebels auf Mitteltunnel / on transmission tunnel  
 Location of the gear lever

e) Übersetzungen  
 Ratios

	Handschaltung Manual			Automatik Automatic			Zusätzl. Getriebe Additional G B		
	Über- setzungen ratio	Anzahl der Zähne number of teeth	synchro	Über- setzungen ratio	Anzahl der Zähne number of teeth	synchro	Über- setzungen ratio	Anzahl der Zähne number of teeth	synchro
1	3,182	35/11	x				1:3,182	35/11	x
2	1,833	33/18	x				1:2,187	35/16	x
3	1,261	29/23	x				1:1,600	32/20	x
4	0,926	21/27	x				1:1,126	29/23	x
5	0,724	21/29	x				1:1,000	26/26	x
Rück- wärts R	3,325	12/21 20/38					3,325	12/21 20/38	
Kon- stante Con- stant									

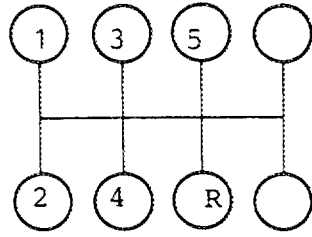
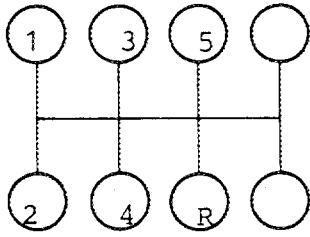

f) Schalt-Schema  
 Gear change gate

604. Schnellgang: a) Art \_\_\_\_\_  
 Overdrive: Type

b) Übersetzung \_\_\_\_\_ c) Anzahl der Zähne \_\_\_\_\_  
 Ratio Number of teeth

d) Vorwärtsgänge, zu denen der Schnellgang zugeschaltet werden kann \_\_\_\_\_  
 Usable with the following gears

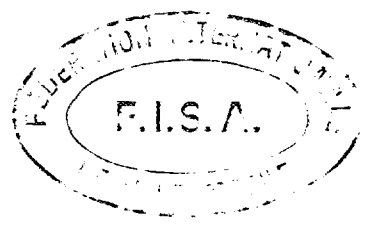

Marke Porsche  
Make

Modell 911 SC  
Model:

Homologation Nr. B-2073  
Homologation Nr.

605. Antriebsachse  
Final drive

Vorn Front	Hinten Rear
	Kegeltellerrad / bevel gear
	4,429
	7:31
	limited slip

e) Übersetzungsverhältnis des Verteilergetriebes \_\_\_\_\_  
Ratio of the transfer box

606. Art der Gelenkwelle Doppelgelenkwellen / double joint shafts  
Type of transmission shaft

7. Radaufhängung  
Suspension

701. Art der Radaufhängung: a) Vorn McPherson Federbein / McPherson strut  
Type of suspension Front

b) Hinten Schräglenker / trailing arm  
Rear

702. Schraubenfedern: Vorn: ~~ja~~ / nein Hinten: ~~ja~~ / nein  
Helicoidal springs: Front: ~~yes~~ / no Rear: ~~yes~~ / no

703. Blattfedern: Vorn: ~~ja~~ / nein Hinten: ~~ja~~ / nein  
Leaf springs: Front: ~~yes~~ / no Rear: ~~yes~~ / no

704. Drehstab: Vorn: ja / ~~nein~~ Hinten: ja / ~~nein~~  
Torsion bar: Front: yes / no Rear: yes / no

705. Andere Arten der Radaufhängung: s. Bild / Zeichnung auf Seite 15  
Other type of suspension. See photo or drawing on page 15

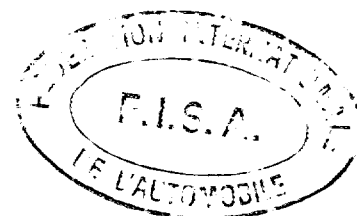

Marke Porsche  
Make

Modell 911 SC  
Model

Homologation Nr. B-207  
Homologation Nr.

707. Stoßdämpfer  
Shock absorbers

Vorn Front	Hinten Rear
<u>1</u>	<u>1</u>
<u>Teleskop / telescopic</u>	<u>Teleskop / telescopic</u>
<u>hydraulisch / hydraulic</u>	<u>hydraulisch/hydraulic</u>

- a) Anzahl je Rad  
Number per wheel:
- b) Art  
Type
- c) Funktionsprinzip  
Working principle

8. Fahrwerk  
Running gear

801. Räder: a) Durchmesser Vorn 15 " / 381 / mm Hinten 15 " / 381 / mm  
Wheels Diameter Front Rear

803. Bremsen: a) Bremssystem hydraulische Zweikreisbremse /  
Brakes Braking system hydraulic double circuit brake

b) Anzahl der Hauptzylinder 1 Tandem b1) Bohrung 19,05 mm  
Number of master cylinders Bore

c) Servo-Bremse  ja  nein c1) Marke und Art \_\_\_\_\_  
Power assisted brakes Make and type

d) Bremskraftregler  ja  nein d1) Lage \_\_\_\_\_  
Braking adjuster Location

Vorn Front	Hinten Rear
<u>2</u>	<u>2</u>
<u>48</u> mm	<u>38</u> mm
<u>mm (± 1,5 mm)</u>	<u>mm (± 1,5 mm)</u>
_____	_____
_____ qcm	_____ qcm
_____ mm	_____ mm
<u>2</u>	<u>2</u>
<u>1</u>	<u>1</u>

e) Anzahl der Zylinder je Rad  
Number of cylinders per wheel

1) Bohrung 48 mm  
Bore

f) Trommelbremsen  
Drum brakes

1) Innendurchmesser \_\_\_\_\_ mm (± 1,5 mm)  
Interior diameter

2) Anzahl der Bremsbacken je Rad \_\_\_\_\_  
Number of shoes per wheel

3) Bremsfläche \_\_\_\_\_ qcm  
Braking surface

4) Breite der Bremsbeläge \_\_\_\_\_ mm  
Width of the shoes

g) Scheibenbremsen  
Disc brakes

1) Anzahl der Bremsbeläge je Rad \_\_\_\_\_  
Number of pads per wheel

2) Anzahl der Sättel je Rad \_\_\_\_\_  
Number of calipers per wheel

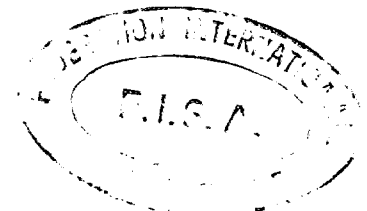



Marke Porsche  
Make

Modell 911 SC  
Model

Homologation Nr. 8-207  
Homologation Nr.

	Vorn Front	Hinten Rear
3) Material der Bremssättel Caliper material	<u>Stahl / steel</u>	<u>Stahl / steel</u>
4) Maximale Dicke der Scheibe Maximum disc thickness	<u>20,5</u> mm	<u>20,0</u> mm
5) Außendurchmesser der Scheibe Exterior diameter of the disc	<u>282,5</u> mm (± 1 mm)	<u>290,0</u> mm (± 1 mm)
6) Außendurchmesser der Belagfläche Exterior diameter of the shoes rubbing surface	<u>280,6 ± 2,3</u> mm	<u>288,1 ± 2,3</u> mm
7) Innendurchmesser der Belagfläche Interior diameter of the shoes rubbing surface	<u>170,0 ± 2,2</u> mm	<u>202,4 ± 2,8</u> mm
8) Länge der Beläge über Alles Overall length of the shoes	<u>76,5</u> mm	<u>61,5</u> mm
9) Belüftete Scheiben Ventilated disc	ja / <del>nein</del> yes / <del>no</del>	ja / <del>nein</del> yes / <del>no</del>
10) Bremsfläche je Rad Braking surface per wheel	<u>782,4</u> qcm	<u>660,0</u> qcm

h) Feststellbremse  
Parking brake

1) Betätigungssystem by cable  
Command system durch Kabel

2) Lage des Bremshebels auf Mittelstunnel  
Location of the lever on transmission tunnel

3) Wirkung auf die Räder ~~Vorn~~ ~~Hinten~~  
On which wheels ~~XXXX~~ ~~XXXX~~

804. Lenkung:

a) Art: Zahnstangenlenkung / rack and pinion steering  
Type

b) Übersetzungsverhältnis 17,78 : 1  
Ratio

c) Lenkhilfe ~~ja~~ / ~~nein~~  
Power assisted ~~yes~~ / ~~no~~

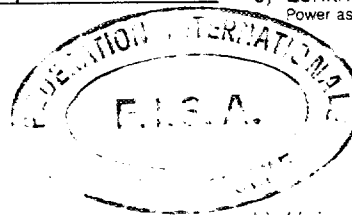

## 9. Karosserie

Bodywork

901. Innen:  
Interior:

a) Belüftung ~~ja~~ / ~~nein~~  
Ventilation ~~yes~~ / ~~no~~

b) Heizung ~~ja~~ / ~~nein~~  
Heating ~~yes~~ / ~~no~~

f) Sonderausstattung Schiebedach ~~ja~~ / ~~nein~~  
Sun roof optional ~~yes~~ / ~~no~~

1) Art Schiebedach / sliding roof  
Type

2) Betätigungssystem elektrisch / electrical  
Command system

g) Öffnungssystem der Seitenscheiben:  
Opening system for the side windows

Vorn durch Kurbelapparat  
Front by crank operation  
Hinten \_\_\_\_\_  
Rear

902 Außen:  
Exterior:

a) Anzahl der Türen 2  
Number of doors

b) Heckklappe ~~ja~~ / ~~nein~~  
Rear tailgate ~~yes~~ / ~~no~~

c) Material der Türen \_\_\_\_\_  
Door material

Vorn Stahl / steel  
Front  
Hinten \_\_\_\_\_  
Rear



Marke Porsche  
Make

Modell 911 SC  
Model

Homologation Nr. B-207  
Homologation Nr.

- d) Material der Fronthaube Stahl / steel  
Front bonnet material
- e) Material der Heckhaube/-klappe Leichtmetall / light alloy  
Rear bonnet / tailgate material
- f) Material der Karosserie Stahl / steel  
Bodywork material
- g) Material der Windschutzscheibe Verbundglas / laminated glass  
Windscreen material
- h) Material der Heckscheibe Sicherheitsglas / safety glass  
Rear window material
- i) Material der hinteren Seitenscheiben Sicherheitsglas / safety glass  
Rear quarter lights material
- k) Material der Seitenscheiben Sicherheitsglas / safety glass  
Side window material  
Vorn front  
Hinten rear
- l) Material der vorderen Stoßstange Leichtmetall / light alloy  
Material of the front bumper
- m) Material der hinteren Stoßstange Leichtmetall / light alloy  
Material of the rear bumper

**Zusätzliche Informationen**  
Complementary informations

S. 5	401c	Material Kraftstofftank Material fuel tank	Kunststoff plastic
S. 7	605b	Achsübersetzung Final drive ratio	4,375 / 5,285 4,375 / 5,285
S. 7	605c	Achsübersetzung Anzahl der Zähne Final drive Number of teeth	8 : 35 / 7 : 37 8 : 35 / 7 : 37
S. 8	801a	Raddurchmesser Wheel diameter	16" / 406,4 mm vorn und hinten 16" / 406,4 mm front and rear



Marke Porsche  
Make

Modell 911 SC  
Model

Homologation Nr. B-207  
Homologation Nr

**Fotos**  
Photos

**Motor**  
Engine

C) Rechte Seitenansicht Motor (ausgebaut)  
Right hand view of dismantled engine

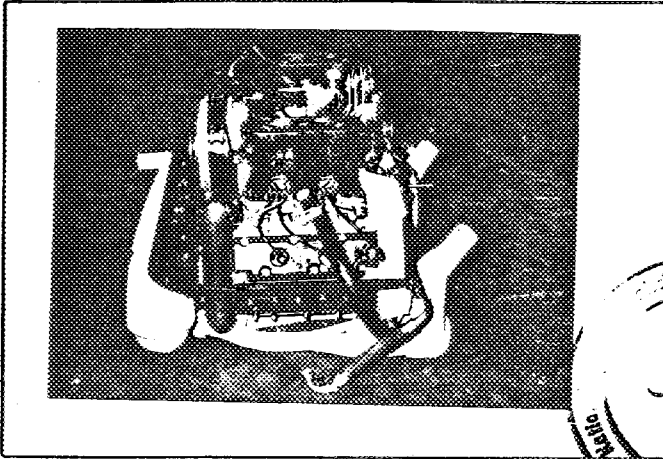

D) Linke Seitenansicht Motor (ausgebaut)  
Left hand view of dismantled engine

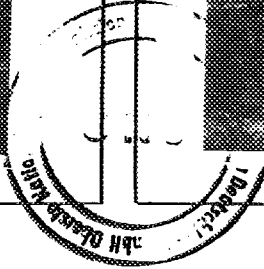
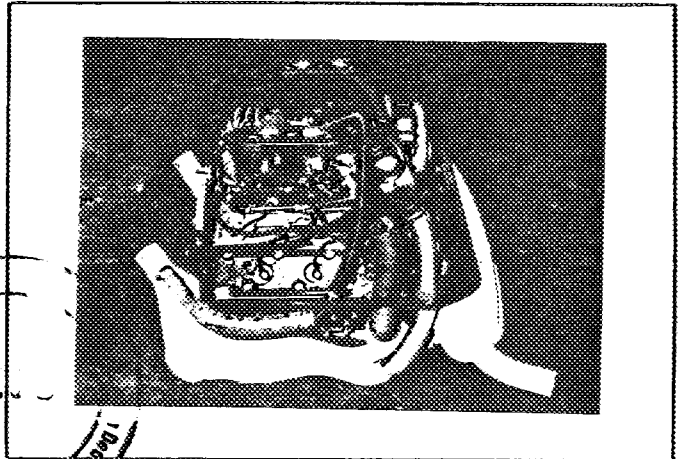

E) Motor im Motorraum  
Engine in its compartment

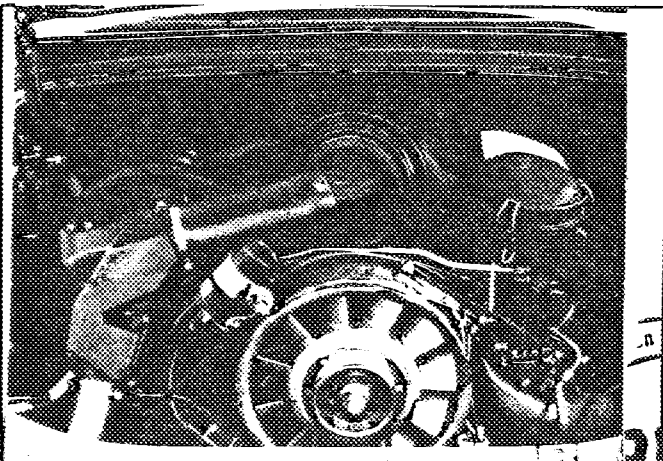

F) Zylinderkopf allein  
Bare cylinderhead

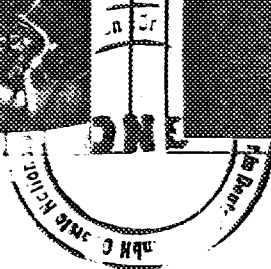
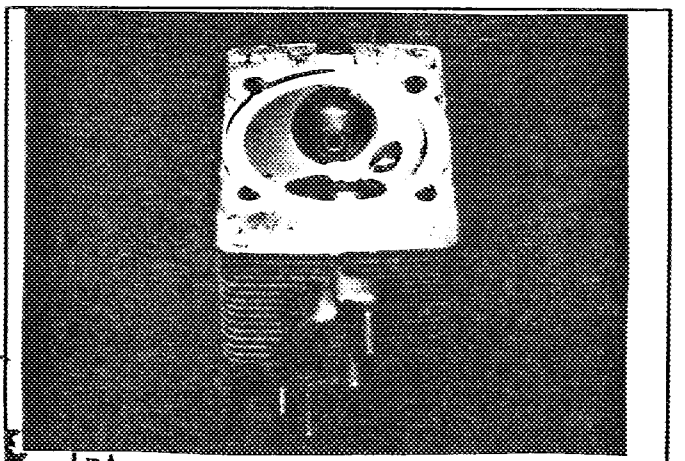

Marke Porsche  
Make

Modell 911 SC  
Model

Homologation Nr. B-207  
Homologation Nr.

G) Verbrennungsraum  
Combustion chamber

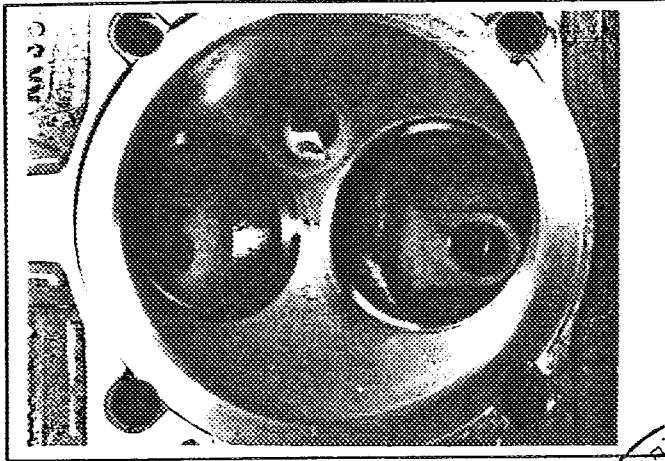

H) Vergaser oder Einspritzsystem  
Carburetor(s) or injection system

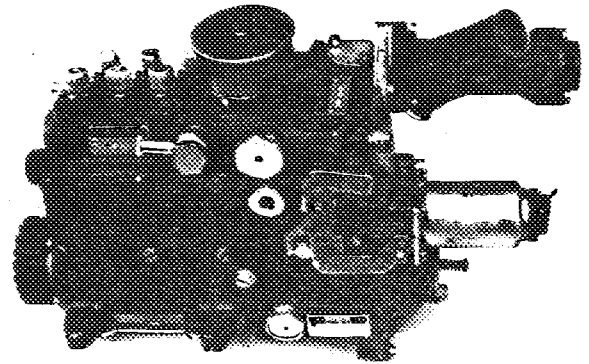

I) Einlaßkrümmer  
Inlet manifold

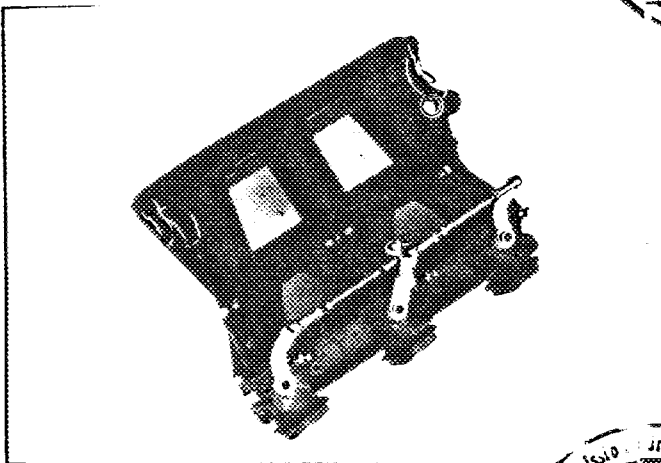

J) Auspußkrümmer  
Exhaust manifold

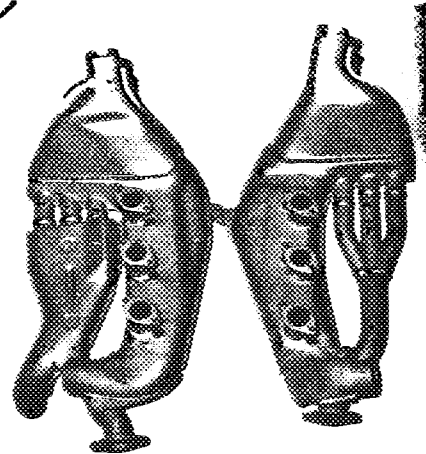

Getriebe  
Transmission

S) Getriebegehäuse und Kupplungsglocke  
Gearbox casing and clutch bellhousing

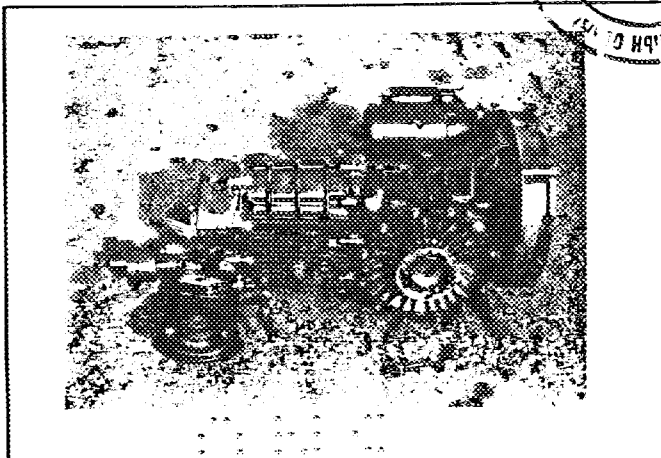

**Radaufhängung**

Suspension

T) Vorderachse vollständig ausgebaut  
Complete dismantled front running gear

U) Hinterachse vollständig ausgebaut  
Complete dismantled rear running gear

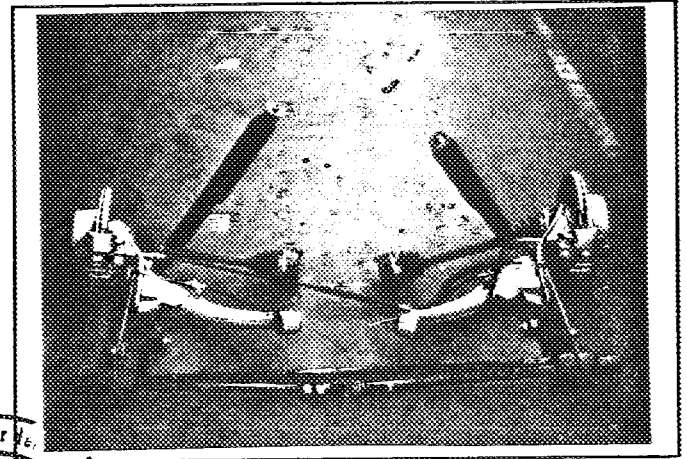
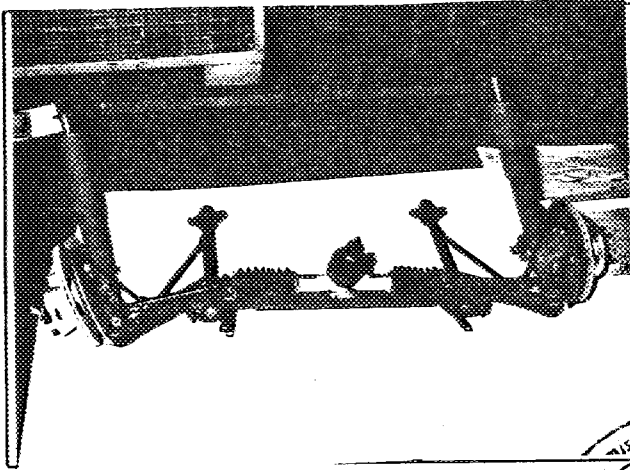

**Fahrwerk**

Running gear

V) Bremsen vorn  
Front brakes

W) Bremsen hinten  
Rear brakes

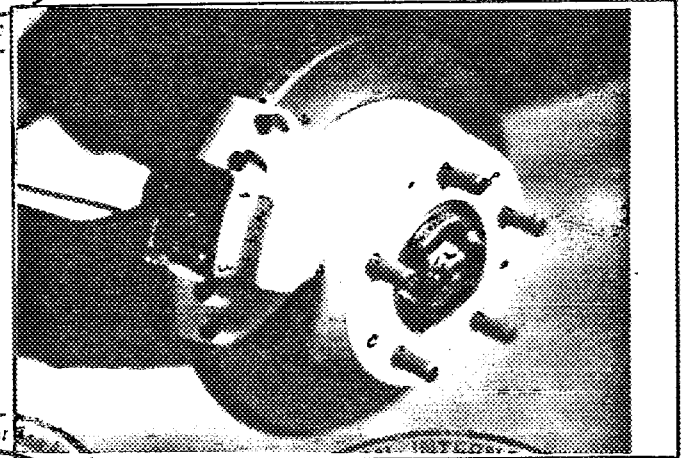
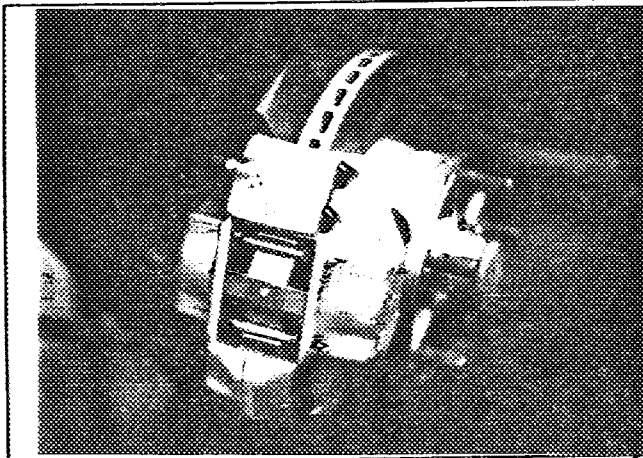
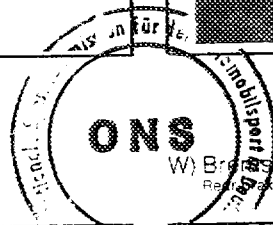

**Karosserie**

Bodywork

X) Armaturenbrett  
Dashboard

Y) Sonnenbedach  
Sunroof

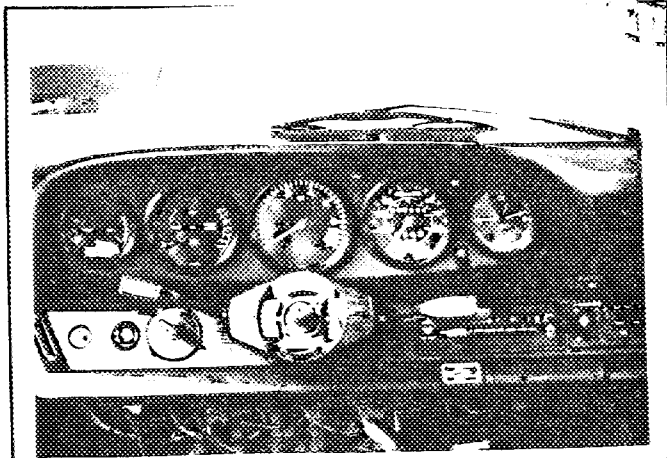
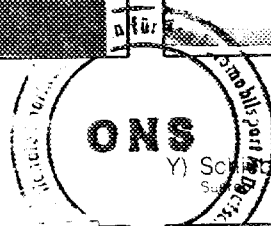

**Zeichnungen**  
Drawings

**Motor**  
Engine

**I. Einlaßöffnungen im Ansaugkrümmer (Abmessungstoleranzen:  $-2\%$ ,  $+4\%$ )**  
Cylinderhead inlet ports, manifold side — tolerances on dimensions:  $-2\%$ ,  $+4\%$

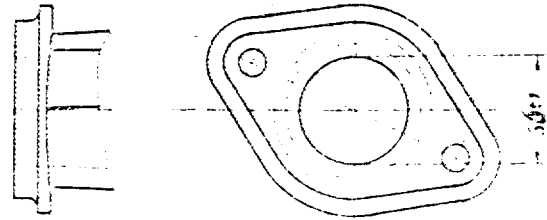

**II. Einlaßöffnungen im Zylinderkopf (Abmessungstoleranzen:  $-2\%$ ,  $+4\%$ )**  
Inlet manifold ports, cylinderhead side — tolerances on dimensions:  $-2\%$ ,  $+4\%$

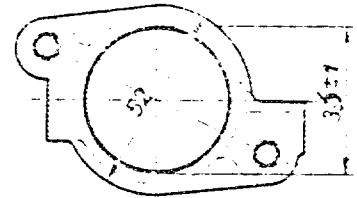

**III. Auslaßöffnungen im Auspuffkrümmer (Abmessungstoleranzen:  $-2\%$ ,  $+4\%$ )**  
Cylinderhead exhaust ports, manifold side — tolerances on dimensions:  $-2\%$ ,  $+4\%$

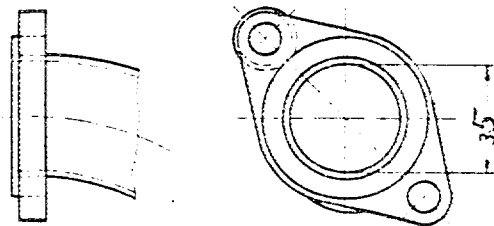

**IV. Auslaßöffnungen im Zylinderkopf (Abmessungstoleranzen:  $-2\%$ ,  $+4\%$ )**  
Exhaust manifold ports, cylinderhead side — tolerances on dimensions:  $-2\%$ ,  $+4\%$

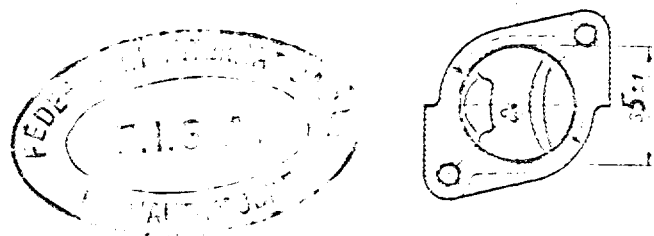

Gruppe **A/B**  
Group

Marke Dr.-Ing.h.c.F.Porsche AG  
Make

Modell 911 SC  
Model

Innenabmessungen gem. Homologationsbestimmungen  
Interior dimensions as defined by the Homologation Regulations

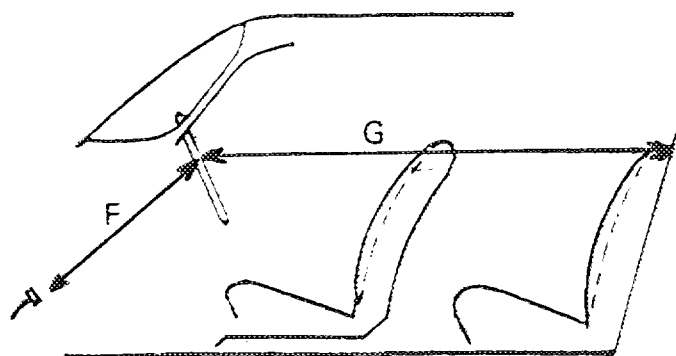
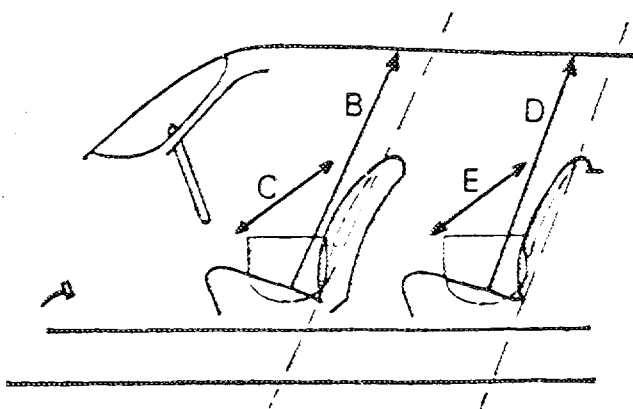

- B Höhe über den Vordersitzen 925 mm  
Height above front seats
- C Breite über den Vordersitzen 1230 mm  
Width at front seats
- D Höhe über den Rücksitzen 831 mm  
Height above rear seats
- E Breite über den Rücksitzen 1190 mm  
Width at rear seats
- F Abstand Lenkrad — Bremspedal 578 mm  
Steering wheel — brake pedal
- G Abstand Lenkrad — Hintere Trennwand 1380 mm  
Steering wheel — rear bulkhead
- H = F + G = 1958 mm

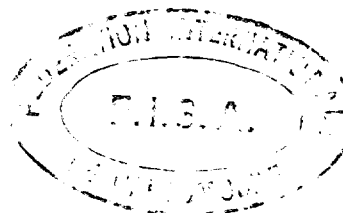

**FÉDÉRATION INTERNATIONALE DU SPORT AUTOMOBILE**  
**ONS Oberste Nationale Sportkommission für den Automobilsport in Deutschland GmbH**

Homologation Nr.

**B - 207**

Nachtrag Nr.  
Extension Nr.

**01 / 01 ET**

**Nachtrag zum offiziellen Testblatt der FISA**

Form of extension to the official FISA-Homologation

**ET** Normale Weiterentwicklung des Typs: ab Fahrgestell -Nr.: \_\_\_\_\_  
 Normal evolution of the type: as from chassis number:

**VF** Liefervariante  
Supply variant

**VO** Ausstattungsvariante  
Option variant

**ER** Berichtigung  
Erratum



Homologation gültig ab: \_\_\_\_\_ -1. MAI 1982  
 Homologation valid as from

in Gruppe:   B    
in group

Hersteller: Dr. Ing. h. c. F. Porsche AG  
 Manufacturer

Modell und Typ: 911 SC  
 Model and type

Seite od. Nachtrag Page or ext	Artikel Art.	Beschreibung Description
S. 11 - 13		Fotos C + D + E + F + H + I + J + T + X Photos
S. 1	103	Gesamthubraum 2994 ccm Cylinder capacity
S. 2	307a	Hubraum pro Zylinder 499 ccm Cylinder capacity, unitary
S. 2	b	Hubraum Gesamt 2994 ccm Cylinder capacity, total
S. 2	c	Hubraum maximal 2999,47 ccm Cylinder capacity, maximum
S. 3	314	Bohrung 95,0 mm Bore
S. 3	315	Maximal zulässige Bohrung 95,11 mm Maximum bore allowed
S. 3	319f	Durchmesser der Kurbelwellen- Hauptlager 60,0 mm Diameter of bearings



Marke Porsche  
 Make

Modell 911 SC  
 Model

Homologations Nr. B-207  
 Homologation Nr.

Nachtrag Nr. 01/01 <sup>ET</sup>  
 Ext. Nr.

Seite od. Nachtrag Page or ext.	Artikel Art.	Beschreibung Description
S. 4	324b	Modell des Einspritzsystems: K-Jetronic  Model of injection system: K-Jetronic
S. 4	d	Abmessungen der Drosselklappen 63 mm Effective dimensions of measure 63 mm position in the throttle area
S. 4	f	Lage der Einspritzventile: im Saugrohr Position of injection valves: in inlet manifold
S. 4	327b	Anzahl der Ansaugkrümmerelemente: 6 Number of manifold elements: 6
S. 4	d	Maximaler Durchmesser der Ventile 49 mm (Einlaß) Maximum diameter of the valves 49 mm (Inlet)
S. 5	328e	Maximaler Durchmesser der Ventile 41,5 mm (Auslaß) Maximum diameter of the valves 41,5 mm (Exhaust)
S. 6	603e	Übersetzungen (Serie): Ratios (Standard):  3,1818 35/11 1,8333 33/18 1,2609 29/23 1,0000 26/26 1,08214 23/28
S. 7	605b	Übersetzungsverhältnis Antriebsachse: 1:3,8750 Ratio of final drive: 1:3,8750
S. 7	605c	Anzahl der Zähne: 8:31 Number of teeth: 8:31



Marke Porsche  
Make

Modell 911 SC  
Model

Homologations Nr. B-207  
Homologation Nr.

Fotos  
Photos

Nachtrag Nr. 01/01 <sup>ET</sup>  
Ext. Nr. ~~138~~

Foto C



Foto D



Foto E

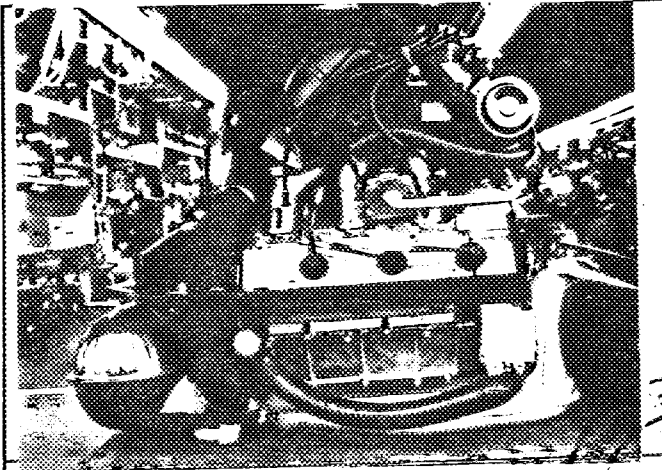

Foto F

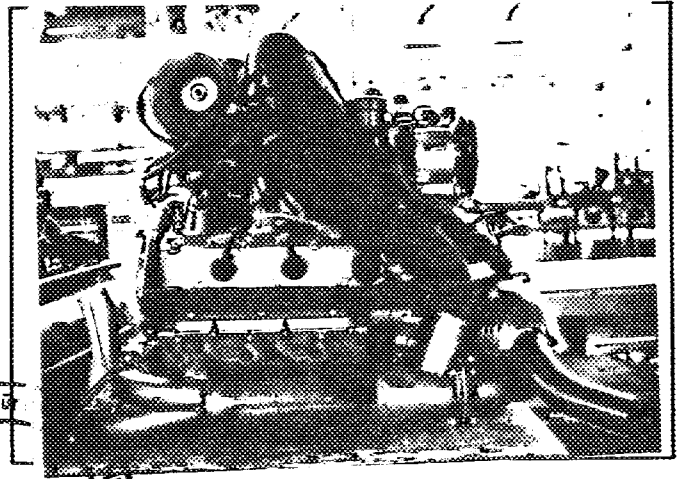

Foto H

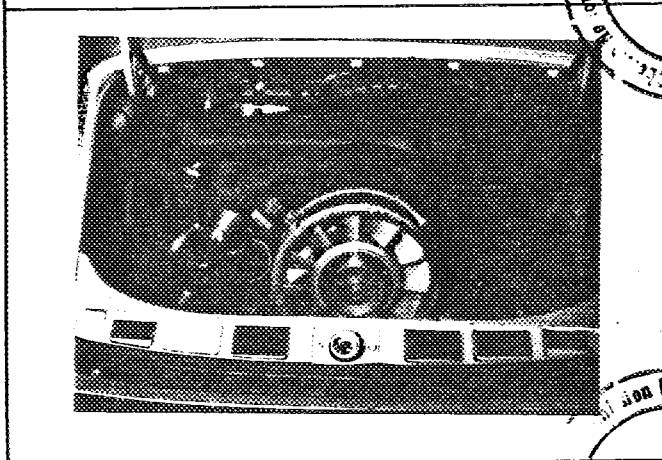

Foto I

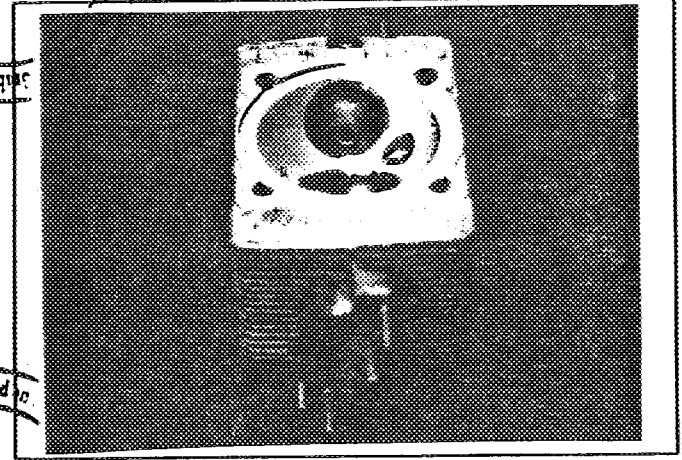

ONS  
ONS  
ONS

Marke Porsche  
Make

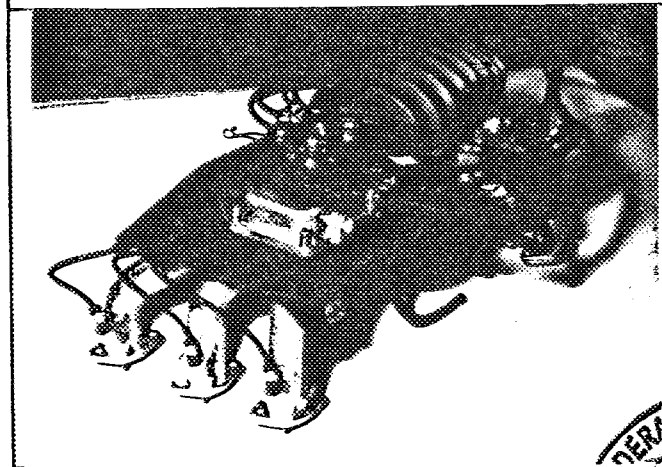
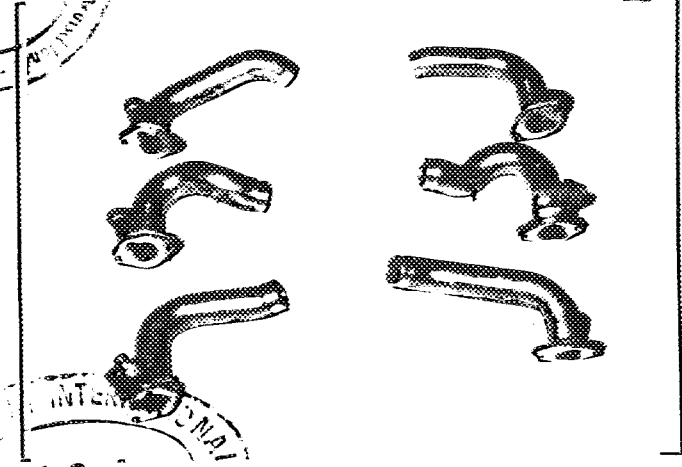
Modell 911 SC  
Model

Homologations Nr. B-207  
Homologation Nr.

Fotos  
Photos

Nachtrag Nr. ET  
Ext. Nr. 01/01

Foto J



Foto T



Foto X

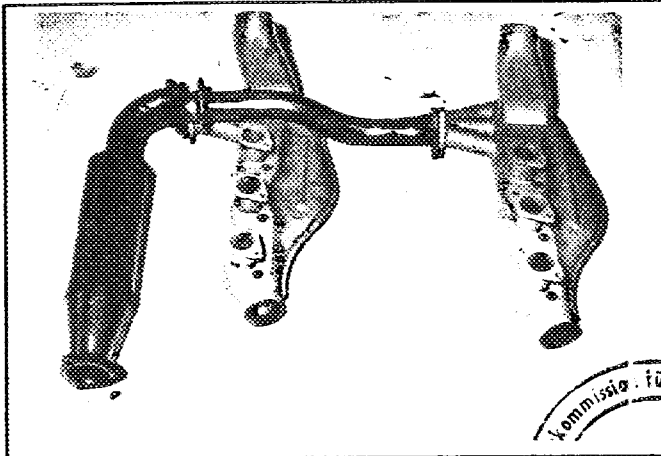

\*\*\*  
\*\*\*  
\*\*\*

Fotos  
Photos

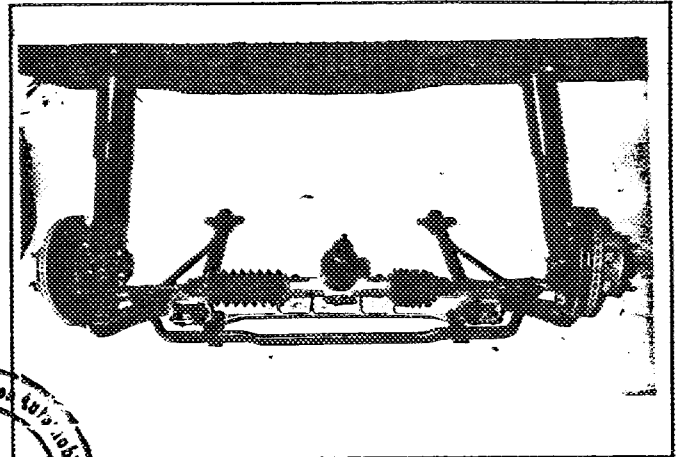
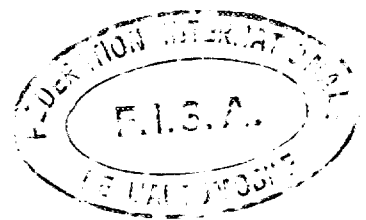
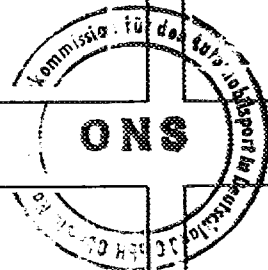
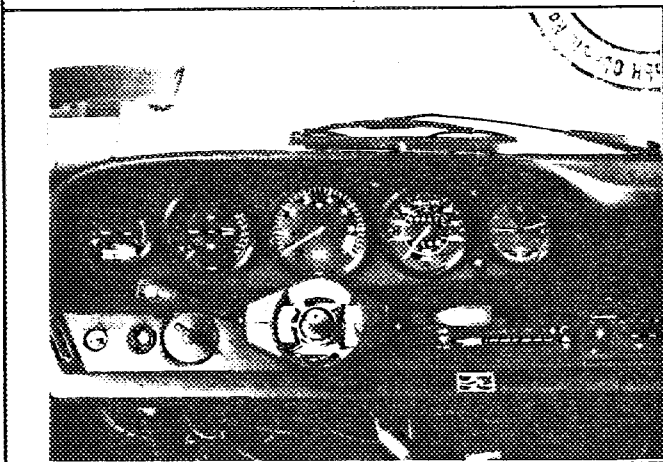
Nachtrag Nr. 02/01V0  
Ext. Nr.

Foto 1



Foto 2



Foto 3

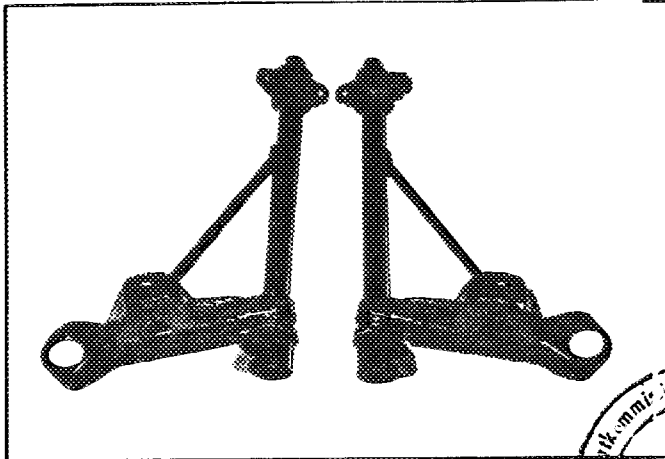

Foto 4

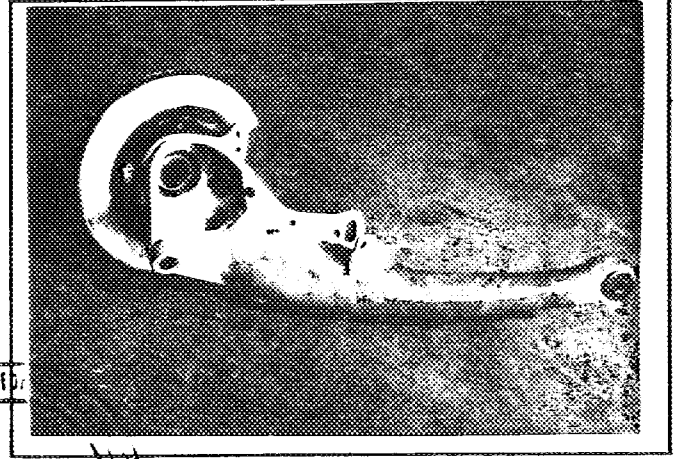

Foto 5

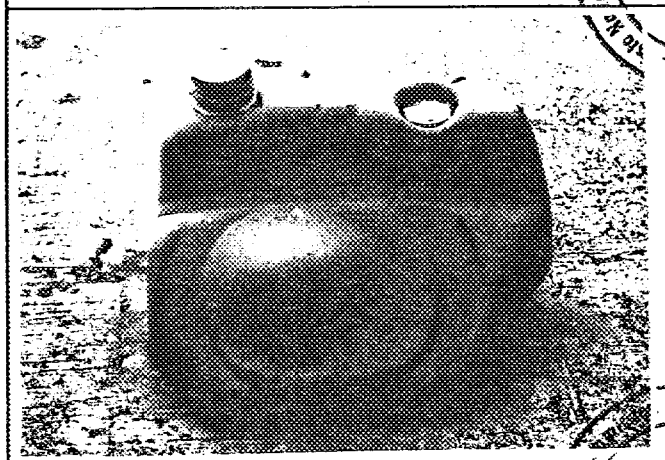

Foto 6

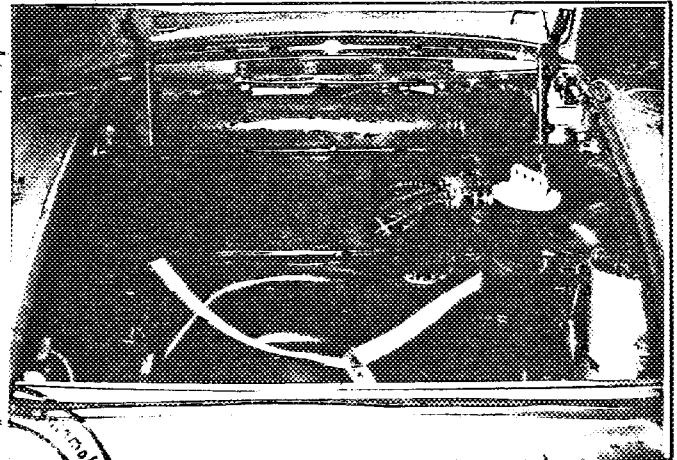

ONS  
ONS  
ONS

**B - 207**

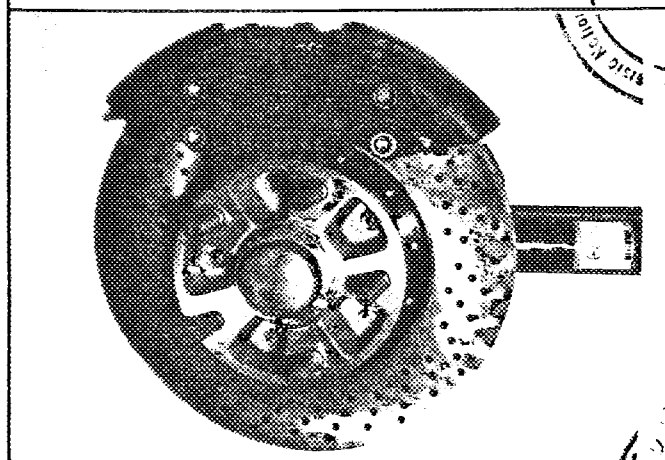
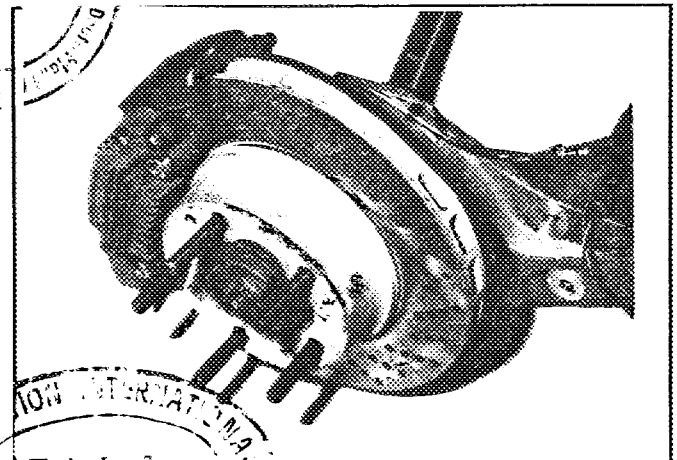
**02 / 01 VO**

Nachtrag zum offiziellen Testblatt der FISA  
 Form of extension to the official FISA-Homologation

- ET Normale Weiterentwicklung des Typs: ab Fahrgestell -Nr.: \_\_\_\_\_  
Normal evolution of the type: as from chassis number:
- VF Liefervariante  
Supply variant
- VO Ausstattungsvariante  
Option variant
- ER Berichtigung  
Erratum

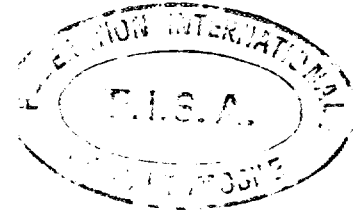

Homologation gültig ab: -1. MAR. 1982 in Gruppe: B  
 Homologation valid as from: \_\_\_\_\_ in group: \_\_\_\_\_

Hersteller: Dr. Ing. h. c. F. Porsche AG Modell und Typ: 911 SC  
 Manufacturer: \_\_\_\_\_ Model and type: \_\_\_\_\_

Seite od. Nachtrag Page or ext.	Artikel Art.	Beschreibung Description	
S. 7	701a	Verstärkte Vorderachslenker Reinforced front wishbone	Foto 1 Photo 1
S. 7	701b	Verstärkte Hinterachslenker Reinforced rear trailing arms	Foto 2 Photo 2
S. 5	401	Kunststofftank 110 Liter Plastic fuel tank 110 Litre	Fotos 3+4 Photos 3+4
S. 8	803	Verbesserte Bremsanlage vorn u. hinten mit 2 Hauptbremszylindern und Waage- balkenausgleich	Fotos 5+6+7
S. 8	803	Improved brake system front and rear with 2 main brake cylinders and balance	Photos 5+6+7
S. 7	701	Aus- und Einfederungsanschlänge an Vorder- und Hinterachse	Fotos 8+9
S. 7	701	Rebound and compression stop on front and rear axle	Photos 8+9
S. 8	803	Hydraulische Handbremse Hydraulic handbrake	Foto 10 Photo 10
S. 8	803	Hydraulische Bremskraftverstellung Hydraulic brake regulator	Foto 11 Photo 11

*[Handwritten signature]*

Marke Porsche Modell 911 SC Homologations Nr. B-207  
 Make \_\_\_\_\_ Model \_\_\_\_\_ Homologation Nr. \_\_\_\_\_

Nachtrag Nr. 02/01V0  
 Ext. Nr. \_\_\_\_\_

Seite od. Nachtrag Page or ext	Artikel Art.	Beschreibung Description	
S. 7	701	Verstärkter Stabilisator vorn und hinten Reinforced stabilizer front and rear	Fotos 14+15 Photos 14+15
S. 6	603	Getriebeölpumpe Gearbox oil pump	Foto 16 Photo 16
S. 5	333	Öltank der Trockensumpfschmierung im Kofferraum Oil tank of dry-sump lubrication in trunk	Foto 17 Photo 17
S. 7	701	Verstärkte Radnaben mit Zentralverschluß vorn und hinten und Bremsenkühlung an Vorderachse Reinforced wheel carriers with central locking front and rear and brake cooling at front axle	Fotos 18+19 Photos 18+19
S. 7	606	Verstärkte Achswellen Reinforced drive shafts	Foto 20 Photo 20



Marque  
Make

Modèle  
Model 911 SC

N° Homol. B-207

N° Ext. 02 / 01 VO

Page ou ext. Page or ext.	Art. Art.	Description Description
PAGE 19.		PHOTOS 5 + 6 + 7
	8Q3 E	NUMBER OF CYLINDERS PER WHEEL 4 FRONT 38 MM REAR 33 MM
	8Q3 G3	MATERIAL OF CALIPERS LIGHT ALLOY FRONT AND REAR
	G4	DISC THICKNESS FRONT 32 MM REAR 29 MM
	G5	EXTERIOR DIAMETER OF DISC FRONT 304 MM REAR 309 MM
	G6	EXTERIOR DIAMETER OF SHOES FRONT 351,8 +/- 1,4 MM REAR 376,8 +/- 1,4 MM
	G7	INTERIOR DIAMETER OF SHOES FRONT 197,8 +/- 1,8 MM REAR 222,8 +/- 0,8 MM
	G8	LENGTH OF SHOES 97,8 MM FRONT AND REAR
	G10	SURFACE PER WHEEL 832,48 QCM FRONT AND REAR



Marque  
Make

Modèle  
Model

911 SC

N° Homol.

B-207

N° Ext.

02 / 01 VO

Page ou ext. Page or ext.	Art. Art.	Description Description
PAGE 20, /		PHOTOS 18 + 19 /
	803 E	NUMBER OF CYLINDERS PER WHEEL 4 FRONT 43 MM REAR 38 MM
	803 G3	MATERIAL OF CALIPERS LIGHT ALLOY
	G4	DISC THICKNESS 29 OR 32 MM
	G5	EXTERIOR DIAMETER OF DISC 304 OR 309 MM
	G6	EXTERIOR DIAMETER OF SHOES 301,8 MM +/- 1,4 MM OR 306,8 MM +/- 1,4 MM
	G7	INTERIOR DIAMETER OF SHOES 197,8 MM +/- 1,8 MM OR 202,8 MM +/- 1,8 MM
	G8	LENGTH OF SHOES 97,8 MM
	G10	SURFACE PER WHEEL 632,48 OCM FRONT AND REAR





Marke  
Make

Porsche

Modell  
Model

911 SC

Homologations Nr.  
Homologation Nr.

B-207

Fotos  
Photos

Nachtrag Nr.  
Ext. Nr.

02 / 01 VO

Foto 7



Foto 8



Foto 9

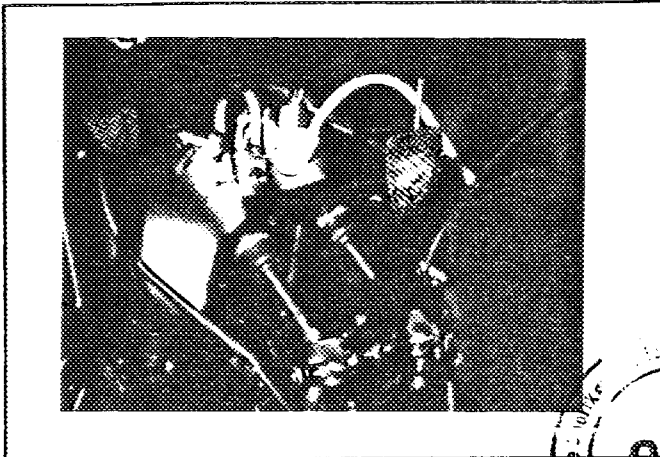

Foto 10



Foto 11

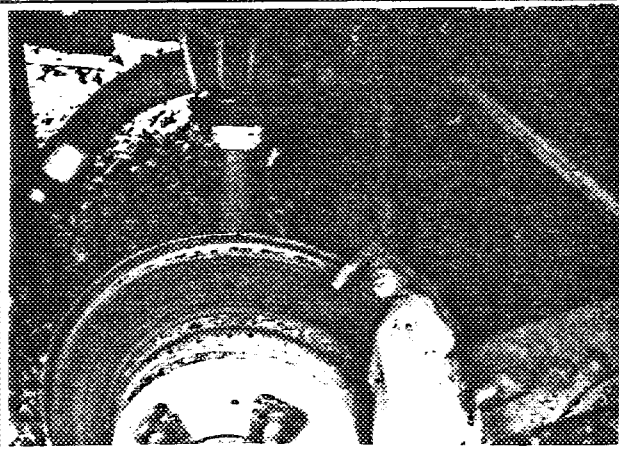

Marke  
Make

Porsche

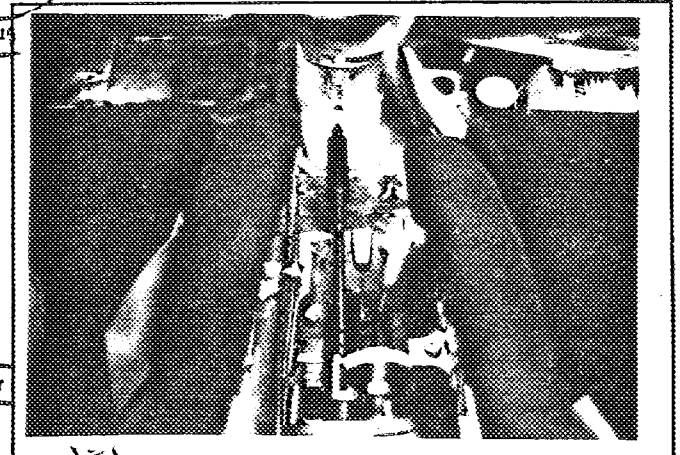
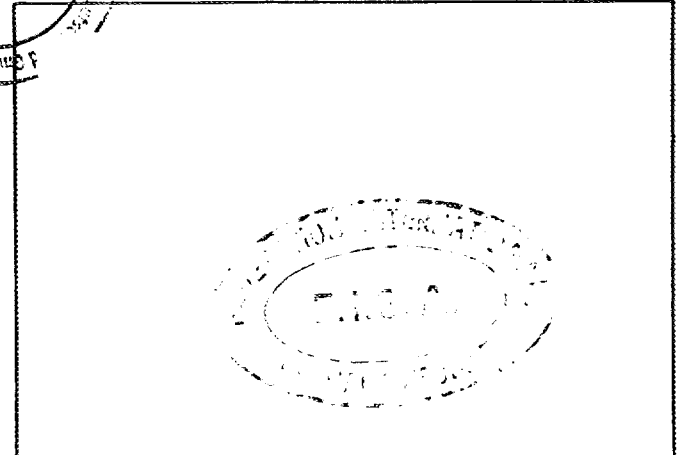
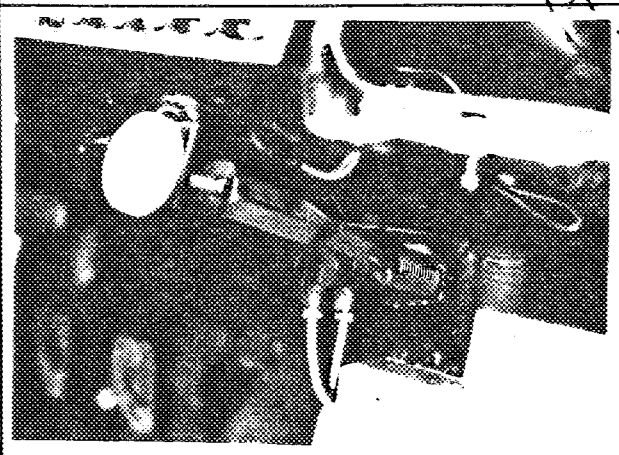
Modell  
Model

911 SC

Homologations Nr.  
Homologation Nr

B-207

Fotos  
Photos

Nachtrag Nr.  
Ext. Nr

02/01V0

Foto 14



Foto 15



Foto 16

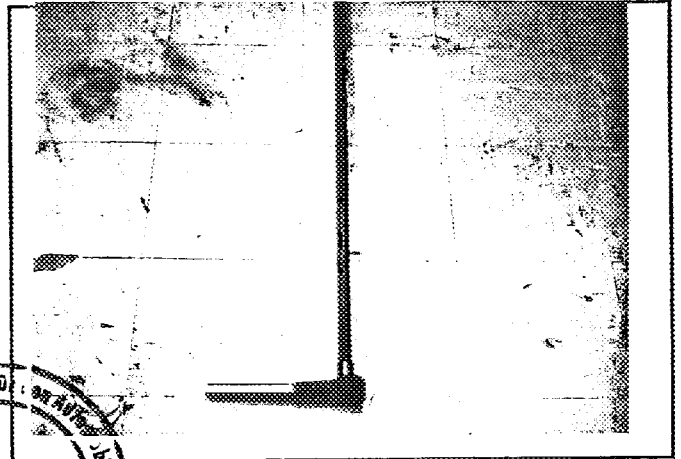

Foto 17

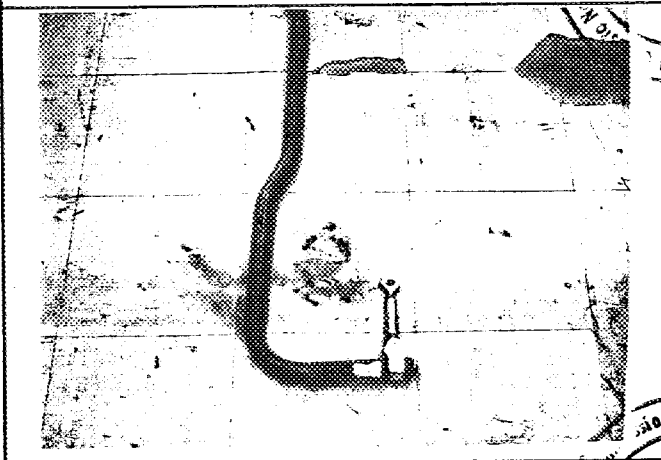

Foto 18

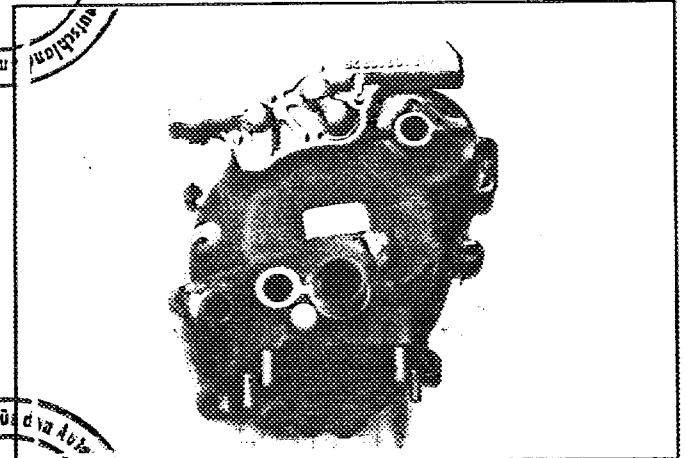

Marke Porsche  
Make

Modell 911 SC  
Model

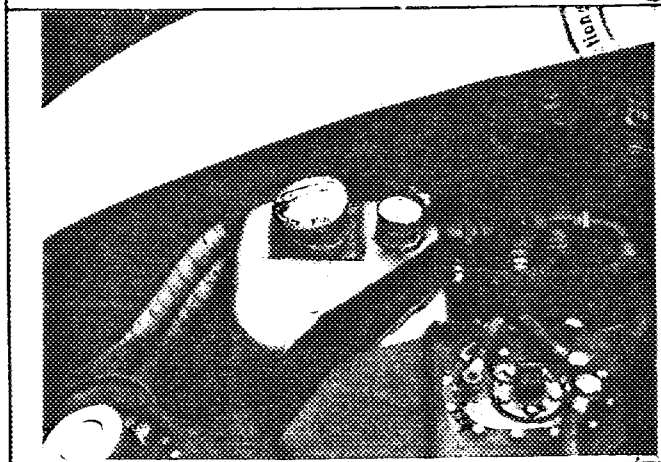
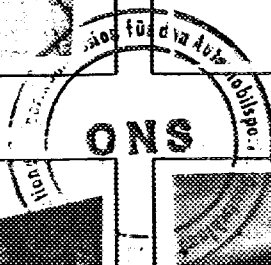
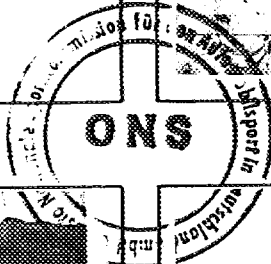
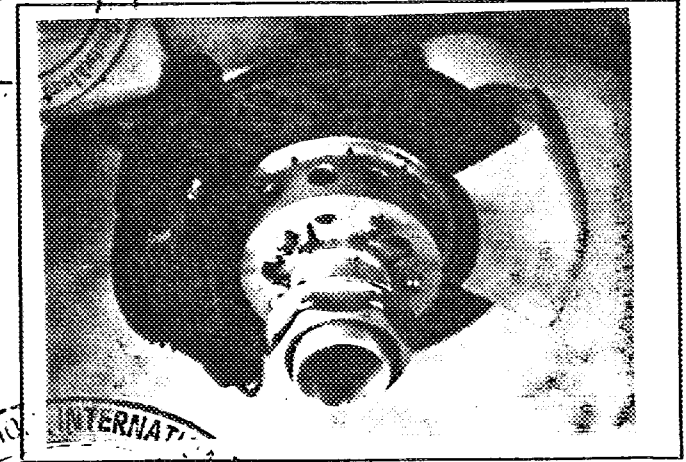
Homologations Nr. B-207  
Homologation Nr.

Fotos  
Photos

Nachtrag Nr. 02/01V0  
Ext. Nr.

Foto 19



Foto 20



\*\*\*  
\*\*\*  
\*\*\*

**B - 207**

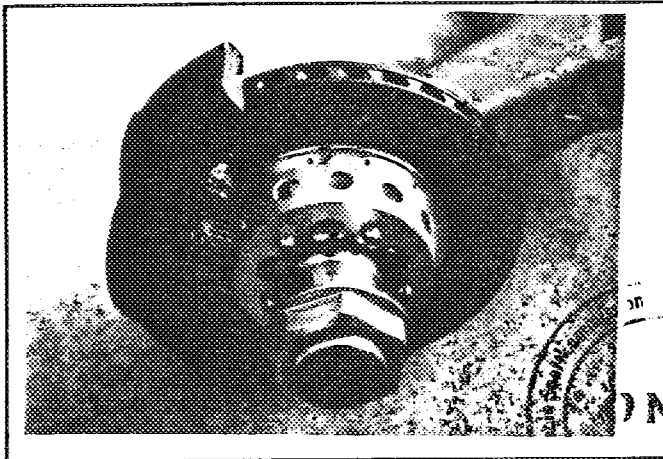
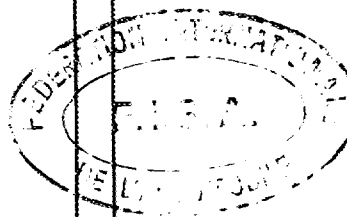
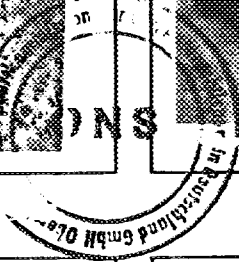
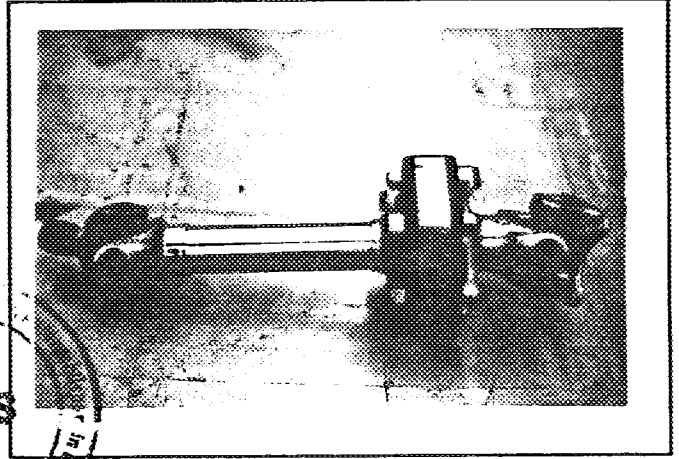
**03 / 02 V**

**Nachtrag zum offiziellen Testblatt der FISA**  
 Form of extension to the official FISA-Homologation

- ET** Normale Weiterentwicklung des Typs: ab Fahrgestell-Nr.: \_\_\_\_\_  
Normal evolution of the type, as from chassis number
- VF** Liefervariante  
Supply variant
- VO** Ausstattungsvariante  
Option variant
- ER** Berichtigung  
Erratum

Homologation gültig ab: \_\_\_\_\_ -1. MAI 1982\_\_\_\_\_ in Gruppe: \_\_\_\_\_ **B** \_\_\_\_\_  
Homologation valid as from in group

Hersteller: Dr. Ing. h. c. F. Porsche AG Modell und Typ: 911 SC  
Manufacturer Model and type

Seite od. Nachtrag Page or ext.	Artikel Art.	Beschreibung Description
S. 1		Fotos A + B Photos A + B
S. 1		Fahrzeug mit Front- u. Heckspoiler      Fotos A+B Vehicle with front and rear spoiler      Photos A+B
S. 10	902e	Material der Heckklappe: Kunststoff Material of rear tailgate: plastic

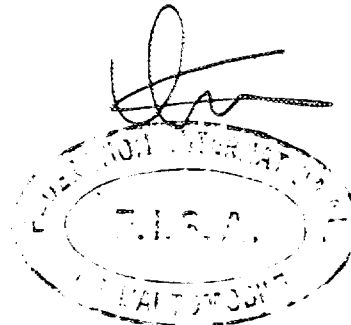

Marke Porsche  
Make

Modell 911 SC  
Model

Homologations Nr. B-207  
Homologation Nr.

Fotos  
Photos

Nachtrag Nr. 03/02V0  
Ext. Nr.

Foto A



Foto B



.....  
.....  
.....

# FÉDÉRATION INTERNATIONALE DU SPORT AUTOMOBILE

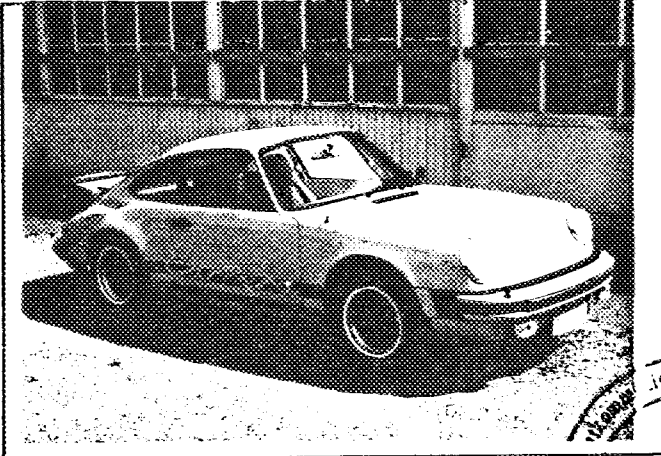
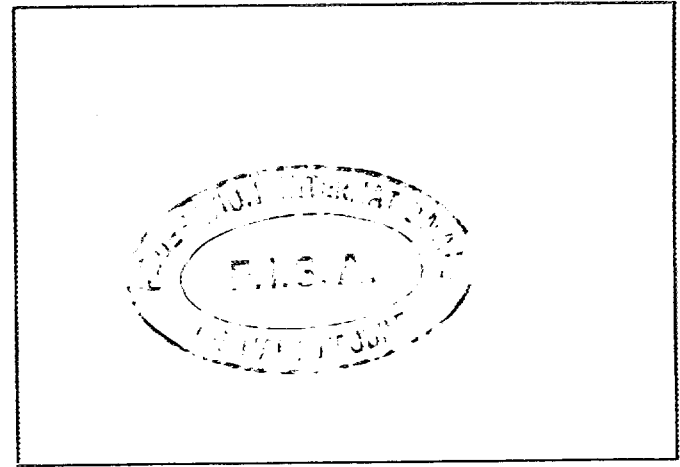
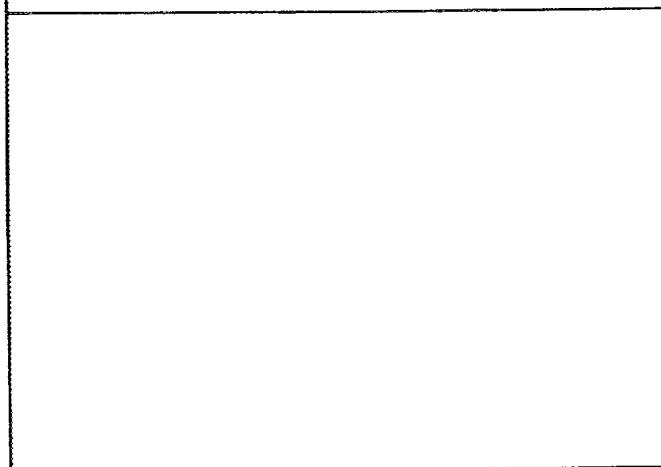
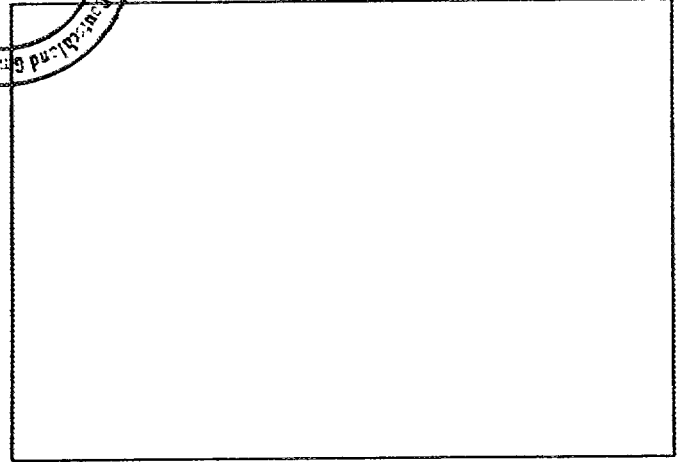
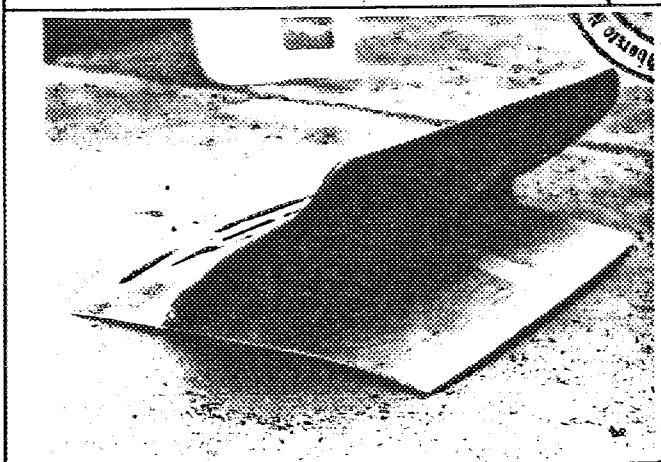
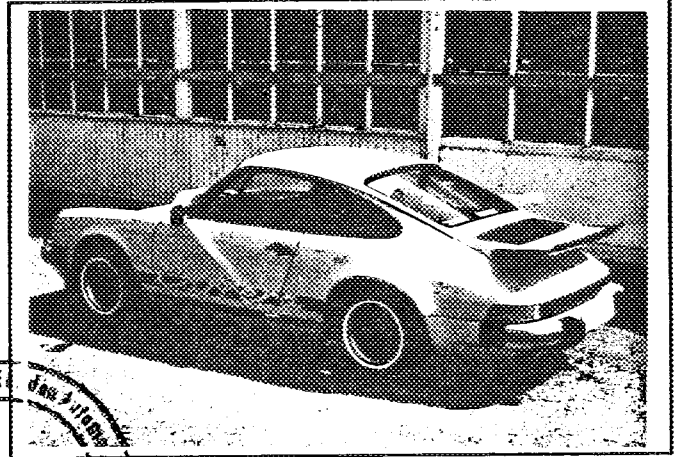
ONS Oberste Nationale Sportkommission für den Automobilsport in Deutschland GmbH

Homologation Nr.

**B-207**

Nachtrag Nr.  
Extension Nr.

**04 / 03 VO**

## Nachtrag zum offiziellen Testblatt der FISA

Form of extension to the official FISA-Homologation

**VO** Ausstattungsvariante  
Option variant

Homologation gültig ab 1. MAR. 1982 in Gruppe B  
Homologation valid as from in group

Fahrzeughersteller Dr.-Ing.h.c.F.Porsche AG Modell und Typ 911 SC  
Manufacturer of the car Model and type

### Überrollbügel/-käfig

Rollbar/rollcage

Hauptbügel  
Main rollbar

Diagonalstrebe  
Longitudinal/diagonal strut

Vorderbügel  
Front rollbar

Bügelhersteller Dr.-Ing.h.c.F.Porsche AG / Matter  
Rollbar manufacturer

Material AL ZN M61 AL ZN M61, AL ZN M61  
Material

Außendurchmesser 40 mm 40 mm/          mm 40 mm  
Exterior diameter

Wandstärke 3 mm 3 mm/          mm 3 mm  
Wall thickness

Streckgrenze 345 kg/mm<sup>2</sup> 345 kg/mm<sup>2</sup>/          kg/mm<sup>2</sup> 345 kg/mm<sup>2</sup>  
Elastic limit

Zugfestigkeit 390 kg/mm<sup>2</sup> 390 kg/mm<sup>2</sup>/          kg/mm<sup>2</sup> 390 kg/mm<sup>2</sup>  
Tensile strength

Gesamtgewicht inkl. Befestigungsvorrichtungen 12 kg  
Total weight including fixings

Kompletter Überrollbügel/-käfig ausgebaut  
Complete rollbar/rollcage outside the car

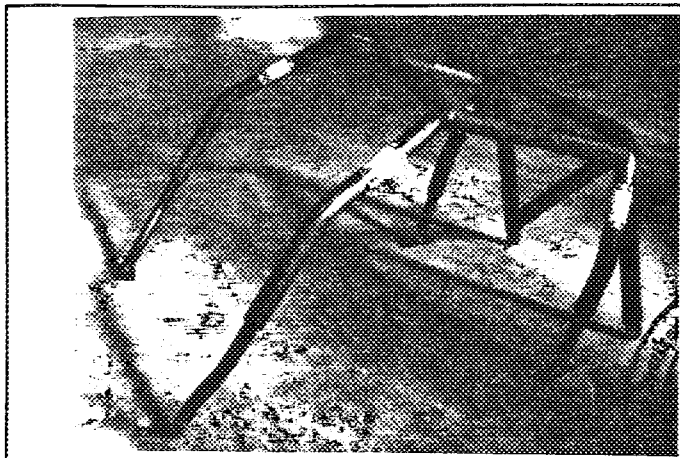

Hiermit wird bestätigt, daß der beschriebene Überrollbügel/-käfig den Anforderungen des Anhangs J der FISA entspricht, insbesondere in Bezug auf seine Befestigungen, Verbindungen und Beanspruchungswerte.

We certify that the present rollbar/rollcage complies with the conditions of the FIA Appendix J, in particular with regard to its attachments, its connections and its stress resistances.

Signature of the manufacturer representative  
**ONS**  
1 GmbH

*Jürgen Barth*  
Jürgen Barth

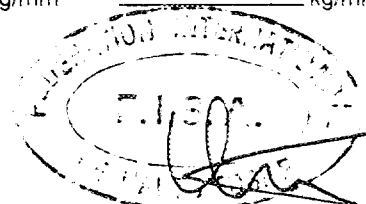

**FÉDÉRATION INTERNATIONALE DU SPORT AUTOMOBILE**  
**ONS Oberste Nationale Sportkommission für den Automobilsport in Deutschland GmbH**

Homologation Nr.

B - 207

Nachtrag Nr.  
Extension Nr.

05 / 01 ER

Nachtrag zum offiziellen Testblatt der FISA  
 Form of extension to the official FISA-Homologation

- ET Normale Weiterentwicklung des Typs: ab Fahrgestell -Nr.: \_\_\_\_\_  
Normal evolution of the type: as from chassis number:
- VF Liefervariante  
Supply variant
- VO Ausstattungsvariante  
Option variant
- ER Berichtigung  
Erratum

- 1 JAN. 1984

Homologation gültig ab: \_\_\_\_\_ in Gruppe: \_\_\_\_\_  
Homologation valid as from in group

Hersteller: Dr.-Ing.h.c.F. Porsche AG Modell und Typ: 911 SC  
Manufacturer Model and type

Seite od. Nachtrag <small>Page or ext.</small>	Artikel <small>Art</small>	Beschreibung <small>Description</small>
16	325d	Anzahl der Lager pro Nockenwelle 4 Number of bearings for each shaft 4  Diese Angaben wurden im Nachtrag 01/01 ET nicht berücksichtigt.  These specifications were not taken into consideration in supplement 01/01 ET.

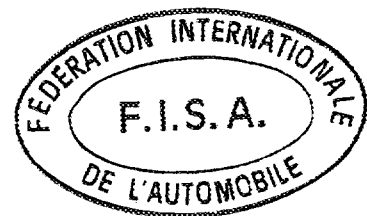
# FÉDÉRATION INTERNATIONALE DU SPORT AUTOMOBILE

ONS Oberste Nationale Sportkommission für den Automobilsport in Deutschland GmbH

Homologation Nr

B - 207

Nachtrag Nr  
Extension Nr

06 / 02 ET

Nachtrag zum offiziellen Testblatt der FISA  
Form of extension to the official FISA-Homologation

ET Normale Weiterentwicklung des Typs: ab Fahrgestell -Nr.: WPO ZZZ 91 ZES 110001  
Normal evolution of the type: as from chassis number:

VF Liefervariante  
Supply variant

VO Ausstattungsvariante  
Option variant

ER Berichtigung  
Erratum

- 1 JAN. 1984

Homologation gültig ab: \_\_\_\_\_ in Gruppe: B  
Homologation valid as from: \_\_\_\_\_ in group:

Hersteller: Dr.-Ing.h.c.F. Porsche AG Modell und Typ: 911 SC  
Manufacturer: \_\_\_\_\_ Model and type: \_\_\_\_\_

Seite od. Nachtrag Page or ext	Artikel Art	Beschreibung Description	
1		Fotos Photos	A + B
2	203	Breite über alles Overall width	1750 mm 1750 mm
2	204a	Breite über Vorderradmitte Width at front axle	1706 mm 1706 mm
	204b	Breite über Hinterradmitte Width at rear axle	1750 mm 1750 mm
4	324b	Modell des Einspritzsystems Model of injection system	Stempelpumpe Injection pump
	324c	Art der Kraftstoffdosierung Kind of fuel measurement	mechanisch mechanical
	c <sub>1</sub>	Kolbenpumpe Piston pump	ja yes
	c <sub>2</sub>	Luftvolumenmessung Measurement of air volume	nein no
	c <sub>3</sub>	Luftmassenmessung Measurement of air mass	nein no



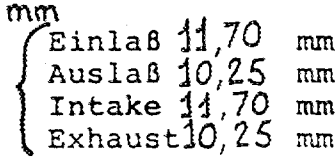

Seite od. Nachtrag Page or est	Artikel Art	Beschreibung Description			
4	324c <sub>4</sub>	Luftgeschwindigkeitsmessung Measurement of air speed	nein no		
	c <sub>5</sub>	Luftdruckmessung Measurement of pressure	nein no		
	324d	Abmessung der Drosselklappen Effective dimensions of measure position in the throttle area	50,0 mm 50,0 mm		
	324g	Teile des Einspritzsystems, die zur Kraftstoffdosierung dienen Statement of fuel measuring of injection system	Einspritzpumpe Injection pump		
	326e	Maximaler Ventilhub Maximum valve lift	<p style="text-align: center;">avec un jeu de: 0,1 mm with clearance of: 0,1 mm</p> <div style="display: flex; align-items: center;"> <div style="margin-right: 10px;"> <p>Einlaß 11,70 mm</p> <p>Auslaß 10,25 mm</p> <p>Intake 11,70 mm</p> <p>Exhaust 10,25 mm</p> </div>  </div>		
	327d	Maximaler Durchmesser der Ventile Maximum diameter of the valves	49 49	mm mm	
	327e	Durchmesser des Ventilschafts Diameter of the valve stem	9 - 0,05 9 - 0,05	mm mm	
	327f	Länge des Ventils Length of the valve	110,1 + 0,25 110,1 - 0,25	mm mm	
	5	328e	Maximaler Durchmesser der Ventile Maximum diameter of the valves	41,5 41,5	mm mm
		328f	Durchmesser des Ventilschafts Diameter of the valve stem	9 + 0,05 9 - 0,05	mm mm
328 g		Länge des Ventils Length of the valve	108,4 + 0,25 108,4 - 0,25	mm mm	

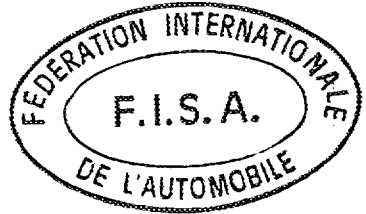

Marke Porsche  
 Make

Modell 911 SC  
 Model

Homologations Nr. B - 207  
 Homologation Nr.

**06 / 02 ET**

Nachtrag Nr. \_\_\_\_\_  
 Est. Nr.

Seite od. Nachtrag Page or ext	Artikel Art	Beschreibung Description
6	603e	Getriebeübersetzungen Gear ratios  Serienübersetzung Standard ratios  1 1 : 3,182 11/35 X 2 1 : 2,000 15/30 X 3 1 : 1,380 21/29 X 4 1 : 1,080 25/27 X 5 1 : 0,888 27/24 X R 1 : 3,325 12/21 20/38  synchro Zusätzliche Getriebeübersetzung Additional gear ratio  1 1 : 3,182 11/35 X 2 1 : 2,187 16/35 X 3 1 : 1,600 20/32 X 4 1 : 1,260 23/29 X 5 1 : 1,000 26/26 X R 1 : 3,325 12/21 20/38  synchro
7	605b	Übersetzungsverhältnis der Antriebsachse 3,875 3,875
	605c	Anzahl der Zähne 8 : 31 Number of teeth 8 : 31
8	801a	Räder-Durchmesser Wheel diameter vorn: 16" / 406,4 mm hinten: 16" / 406,4 mm front: 16" / 406,4 mm rear: 16" / 406,4 mm
	803b	Anzahl der Haupt- bremszylinder 2 Number of master brake cylinders 2
	b <sub>1</sub>	Bohrung des Haupt- bremszylinders 17 / 22 mm Bore of master brake cylinders 17 / 22 mm
	803c	Servo-Bremse nein Power assisted brake no

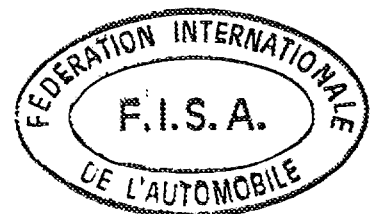

**06 / 02 ET**

Nachtrag Nr. \_\_\_\_\_  
 Ext. Nr. \_\_\_\_\_

Seite od. Nachtrag Page or ext	Artikel Art	Beschreibung Description				
8	803e	Anzahl der Zylinder je Rad	4	vorn	38 mm	
				hinten	30 mm	
		Number of dylinders per wheel	4	front	38 mm	
				rear	30 mm	
9	803g <sub>3</sub>	Material der Bremssättel Material of calipers		Leichtmetall Light alloy	(vorn + hinten) (front + rear)	
	g <sub>4</sub>	Maximale Dicke der Scheibe Maximum disc thickness		vorn hinten	32 mm 28 mm	
				front rear	32 mm 28 mm	
	g <sub>5</sub>	Außendurchmesser der Scheibe Exterior diameter of disc		vorn hinten	304 mm 309 mm	
				front rear	304 mm 309 mm	
	g <sub>6</sub>	Außendurchmesser der Belag- fläche Exterior diameter of the shoes rubbing surface		vorn hinten	301,8 mm 306,8 mm	+ 1,4 + 1,4
				front rear	301,8 mm 306,8 mm	+ 1,4 - 1,4
	g <sub>7</sub>	Innendurchmesser der Belag- fläche Interior diameter of the shoes rubbing surface		vorn hinten	197,8 mm 202,8 mm	+ 1,5 + 0,8
				front rear	197,8 mm 202,8 mm	+ 1,5 - 0,8
	g <sub>8</sub>	Länge der Beläge über Alles Overall length of the shoeas		vorn hinten	97,8 mm 97,8 mm	
				front rear	97,8 mm 97,8 mm	
	g <sub>10</sub>	Bremsfläche je Rad Braking surface per wheel		vorn hinten	832,48 cm <sup>2</sup> 832,48 cm <sup>2</sup>	
				front rear	832,48 cm <sup>2</sup> 832,48 cm <sup>2</sup>	
	902c	Material der Türen Door material		vorn front	Aluminium aluminum	

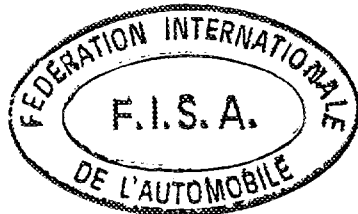

Marke Porsche  
 Make

Modell 911 SC  
 Model

Homologations Nr. B - 207  
 Homologation No.

**06 / 02 ET**

Nachtrag Nr. \_\_\_\_\_  
 Ext. No.

Seite od. Nachtrag Page or ext.	Artikel Art	Beschreibung Description	
10	902d	Material der Fronthaube Front bonnet material	Aluminium aluminum
	902e	Material der Heckhaube Rear bonnet material	Stahl/Plastik steel/plastic
	902f	Material der Karosserie Bodywork material	Stahl steel
	902l	Material der vorderen Stoß- stange Material of front bumper	Plastik plastic
	902m	Material der hinteren Stoß- stange Material of rear bumper	Plastik plastic
	605b	Achsübersetzung Final drive ratio	4,375 / 4,714 4,375 / 4,714
	605c	Anzahl der Zähne Number of teeth	8 : 35 / 7 : 33 8 : 35 / 7 : 33
11		Fotos Photos	C / D / E / F
12		Fotos Photos	G / H / I / J / S / T
13		Fotos Photos	U / V / W / X
14		Zeichnungen Ansaugkrümmer / Drawings of the manifold /	Auslaßkrümmer exhaust manifold

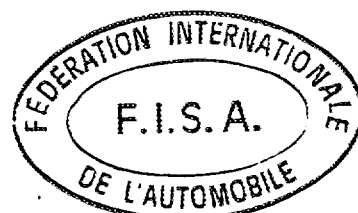

**Zelchnungen**  
Drawings

**Motor**  
Engine

**I. Einlaßöffnungen im Ansaugkrümmer (Abmessungstoleranzen: - 2 %, + 4 %)**  
Cylinderhead inlet ports, manifold side — tolerances on dimensions: - 2 %, + 4 %

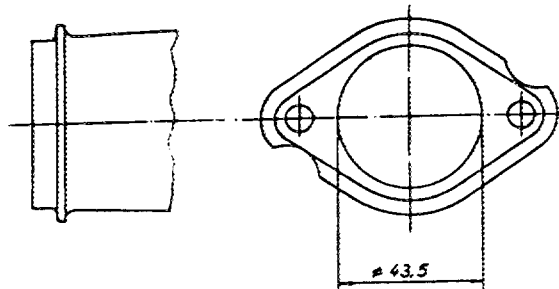

**II. Einlaßöffnungen im Zylinderkopf (Abmessungstoleranzen: - 2 %, + 4 %)**  
Inlet manifold ports, cylinderhead side — tolerances on dimensions: - 2 %, + 4 %

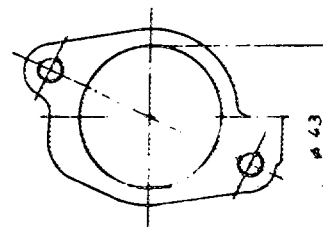

**III. Auslaßöffnungen im Auspuffkrümmer (Abmessungstoleranzen: - 2 %, + 4 %)**  
Cylinderhead exhaust ports, manifold side — tolerances on dimensions: - 2 %, + 4 %

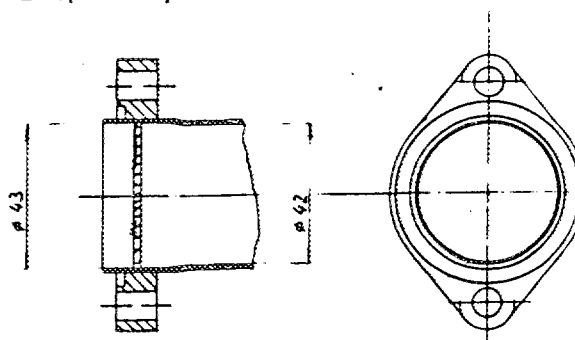

**IV. Auslaßöffnungen im Zylinderkopf (Abmessungstoleranzen: - 2 %, + 4 %)**  
Exhaust manifold ports, cylinderhead side — tolerances on dimensions: - 2 %, + 4 %

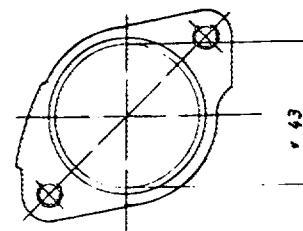
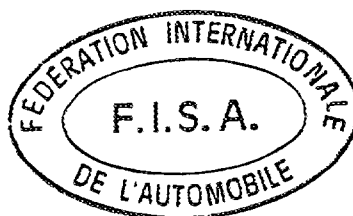

Fotos  
Photos

Foto A



Foto B



Foto C

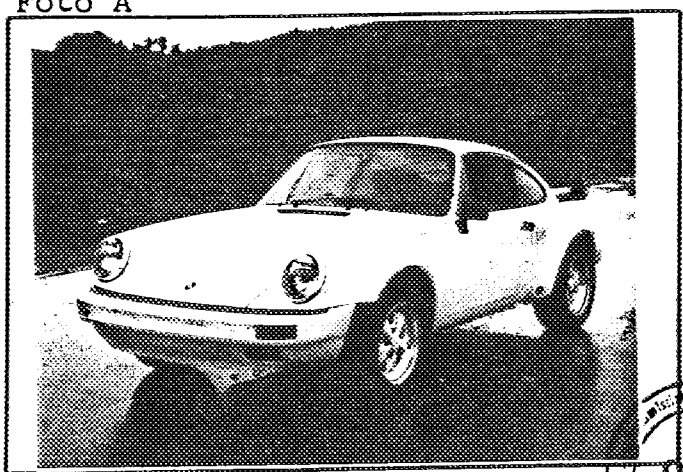

Foto D

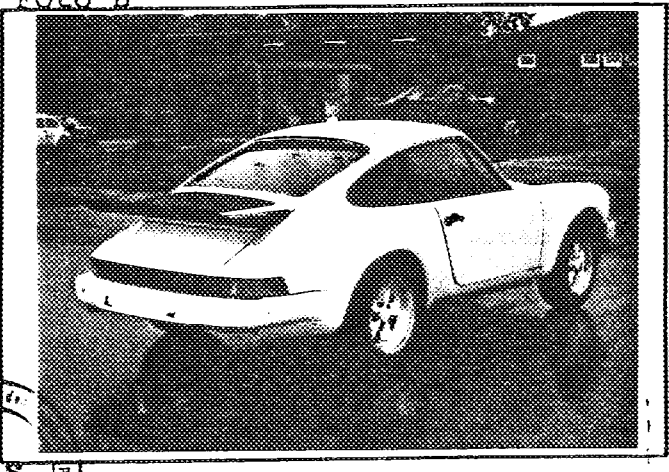

Foto E

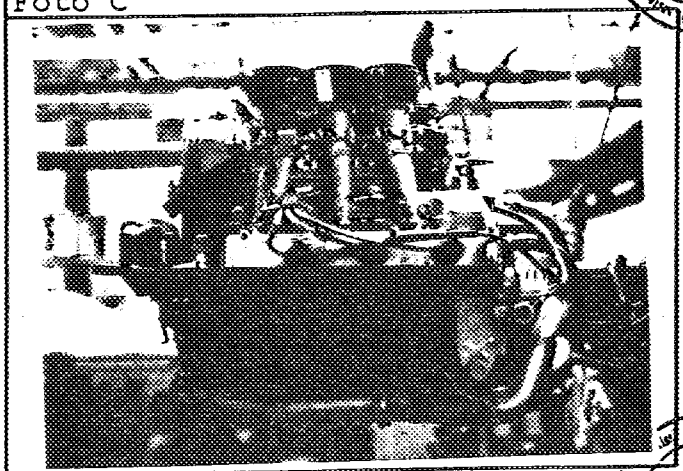

Foto F

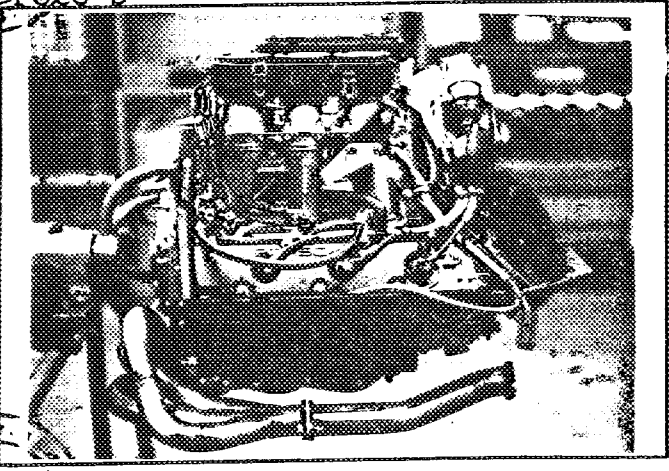

Marke Porsche  
Modell

911 SC  
Modell

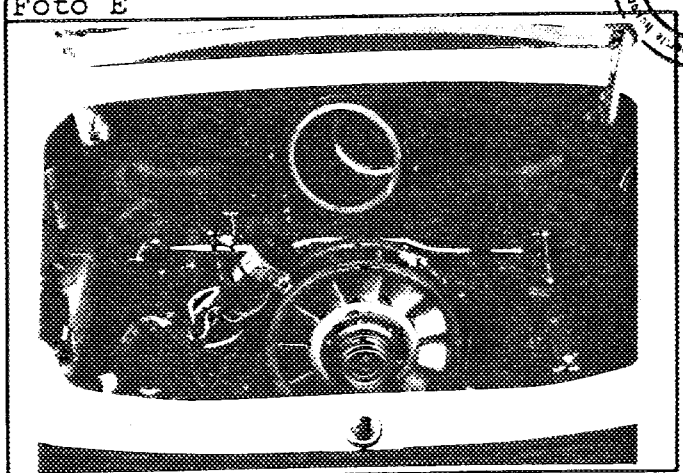
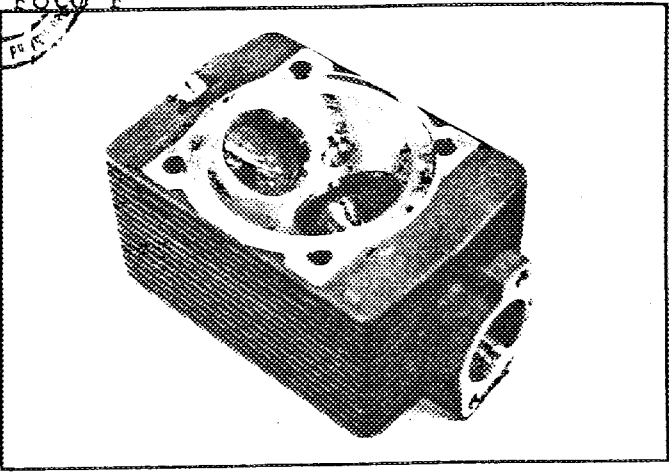
Homologations Nr. B - 207  
Homologation Nr.

06/02 ET

Fotos  
Photos

Nachtrag Nr. \_\_\_\_\_  
Ext. Nr. \_\_\_\_\_

Foto G



Foto H



Foto I

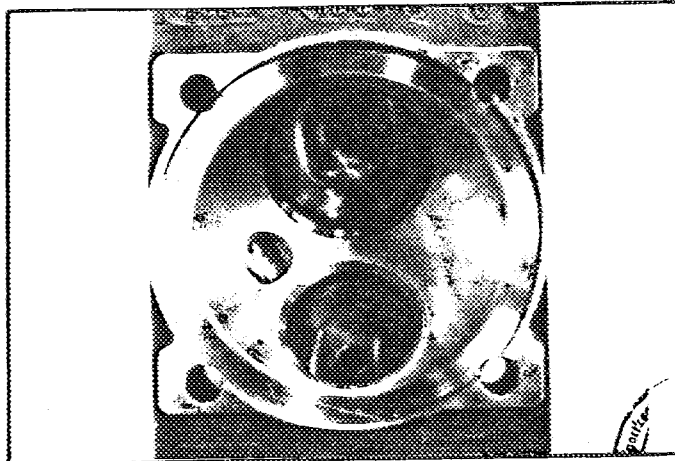

Foto J

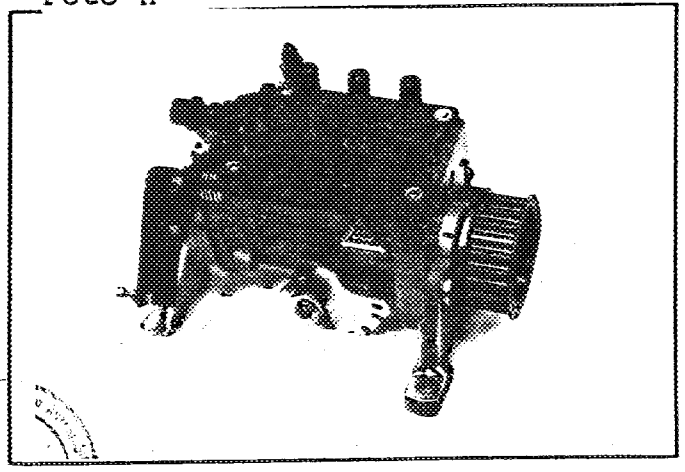

Foto S

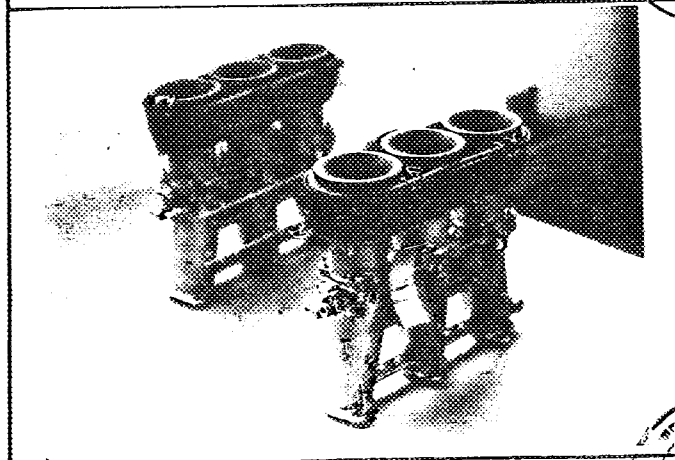

Foto T

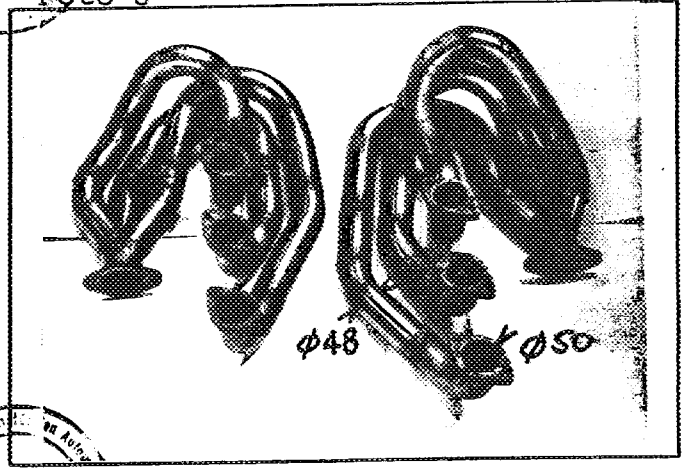

Marke Porsche

Modell 911 SC

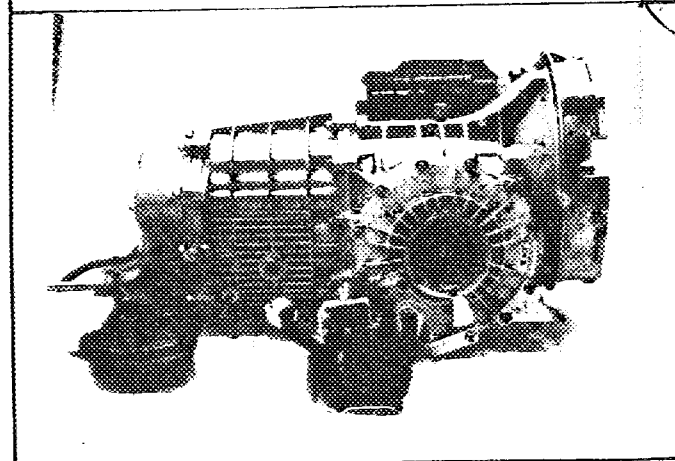
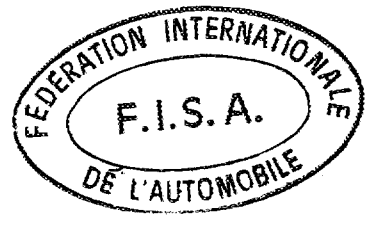
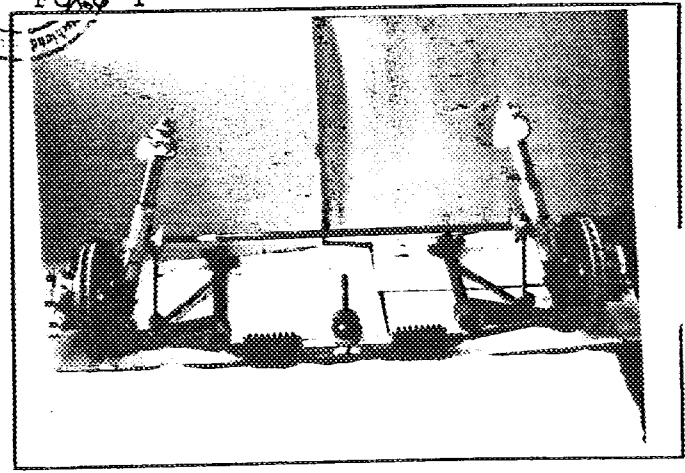
Homologations Nr. B - 207

Fotos  
Photo

Nachtrag Nr. 06/02 ET  
Ext. Nr.

Foto U



Foto V



Foto W

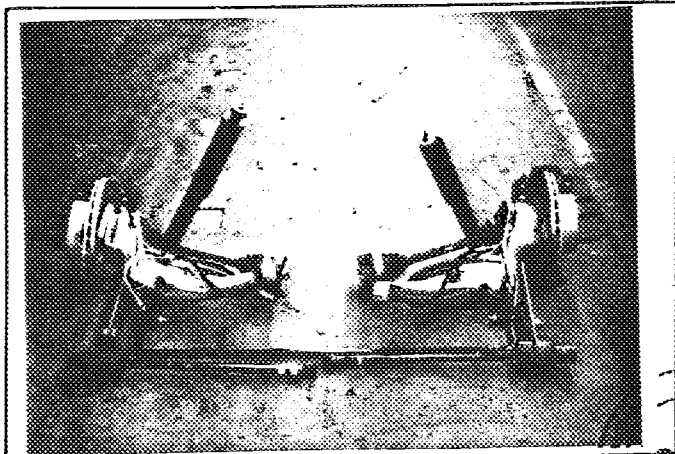

Foto X



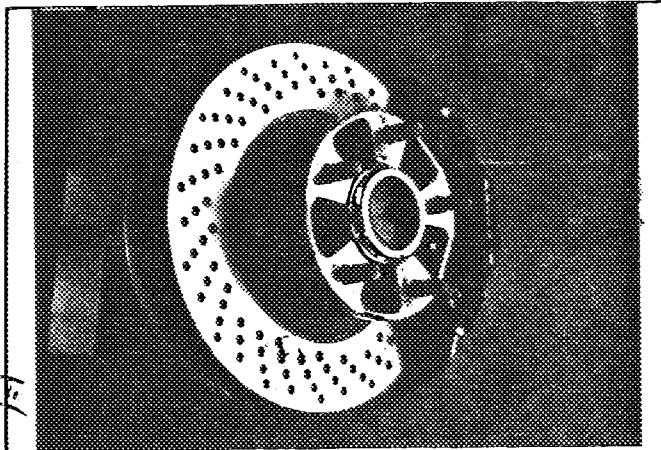

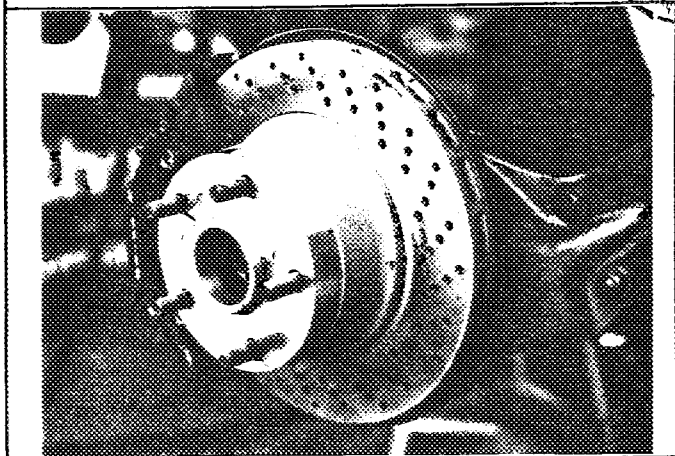
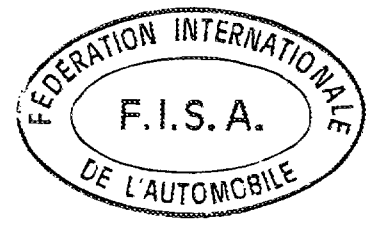
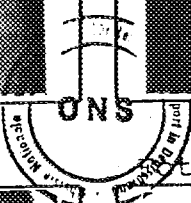
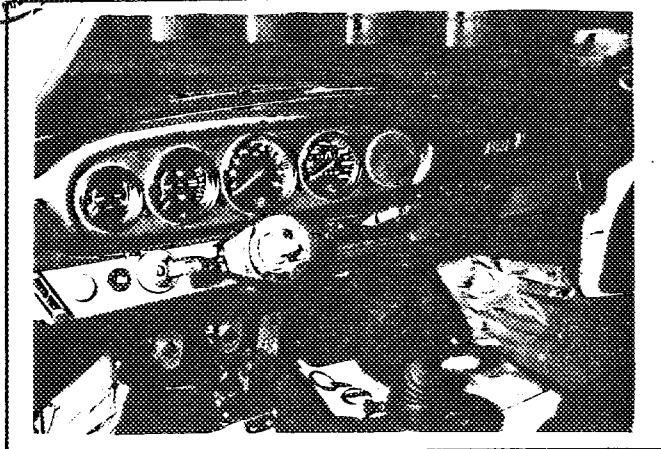

# FEDERATION INTERNATIONALE DU SPORT AUTOMOBILE

Homologation N°

**B-207**

Extension N°

**07/02 ER**

FICHE D'EXTENSION A L'HOMOLOGATION OFFICIELLE FISA  
FORM OF EXTENSION TO THE OFFICIAL FISA HOMOLOGATION

- ET** Evolution normale du type: dès le numéro de châssis  
Normal evolution of the type: as from chassis number \_\_\_\_\_
- VF** Variante de fourniture / Supply variant
- VO** Variante option / Option variant
- ER** Errata / Erratum

Homologation valable dès le **- 1 SEP. 1984** en groupe **B**  
Homologation valid as from \_\_\_\_\_ in group \_\_\_\_\_

Constructeur **Porsche** Modèle et type **911 SC**  
Manufacturer \_\_\_\_\_ Model and type \_\_\_\_\_

Page ou ext. Page or ext.	Art. Art.	Description Description
12	photo J	Ø de la sortie du collecteur d'échappement :
12	photo J	Ø of the exhaust manifold exit. :
12	photo J	<u>50,0</u> mm
01/01 ET p. 18	photo J	<u>60,5</u> mm

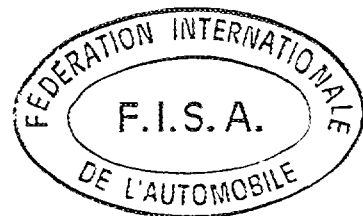

# FÉDÉRATION INTERNATIONALE DU SPORT AUTOMOBILE

ONS Oberste Nationale Sportkommission für den Automobilsport in Deutschland GmbH

Homologation Nr.

B 207

Nachtrag Nr.  
Extension Nr.

08 / 04 VO

## Nachtrag zum offiziellen Testblatt der FISA

Form of extension to the official FISA-Homologation

**ET** Normale Weiterentwicklung des Typs: ab Fahrgestell-Nr.: \_\_\_\_\_  
Normal evolution of the type: as from chassis number:

**VF** Liefervariante  
Supply variant

**VO** Ausstattungsvariante  
Option variant

**ER** Berichtigung  
Erratum

- 1 DEC. 1984

Homologation gültig ab: \_\_\_\_\_  
Homologation valid as from:

in Gruppe: B  
in group

Hersteller: Dr.-Ing.h.c.F. Porsche AG  
Manufacturer

Modell und Typ: 911 SC  
Model and type

Seite od. Nachtrag Page or ext.	Artikel Art.	Beschreibung Description	
7	701	Aus- und Einfederanschläge an Vorder- und Hinterachse Rebound and compression stop on front and rear axle	Foto 1 Photo 1
7	701	Verstärkte Hinterachs-Federstreben Heavy duty rear suspension support	Foto 2 Photo 2
8	803	Verbesserte Bremssättel vorn 38 mm hinten 38 mm Improved brake calipers front 38 mm rear 38 mm	Foto 3 Photo 3
8	803b	Bohrung des Hauptbremszylinders 15,9 / 17,8 / 19,1 mm Bore of master brake cylinder 15,9 / 17,8 / 19,1 mm	
9	804	Alternative Lenkübersetzung 15,94 : 1 Alternative steering ratio 15,94 : 1	

*[Signature]*

FEDERATION INTERNATIONALE  
F.I.S.A.  
AUTOMOBILE  
Seite (Page) 1/

Marke Porsche  
Make

Modell 911 SC  
Model

Homologations Nr. B 207  
Homologation Nr

Fotos  
Photos

Nachtrag Nr. 08 / 04 VO  
Ext. Nr



Foto 1



Foto 2

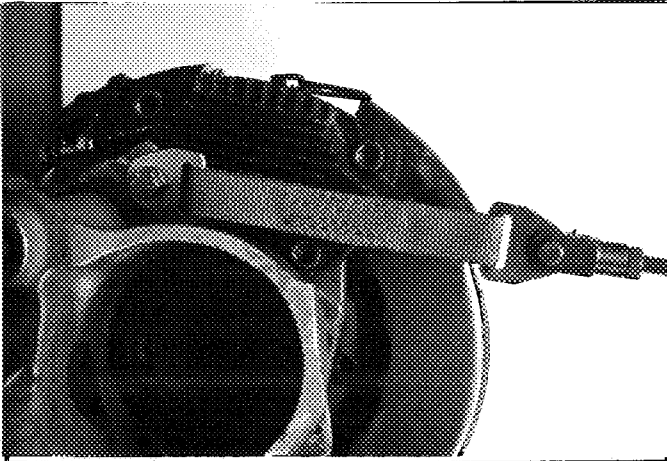

Foto 3



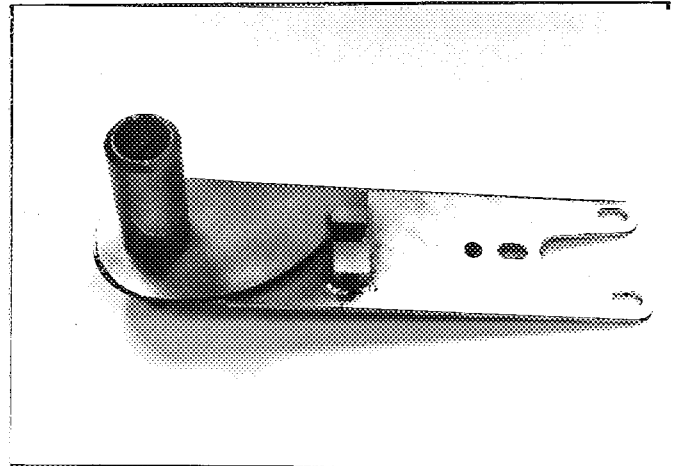

# FEDERATION INTERNATIONALE DU SPORT AUTOMOBILE

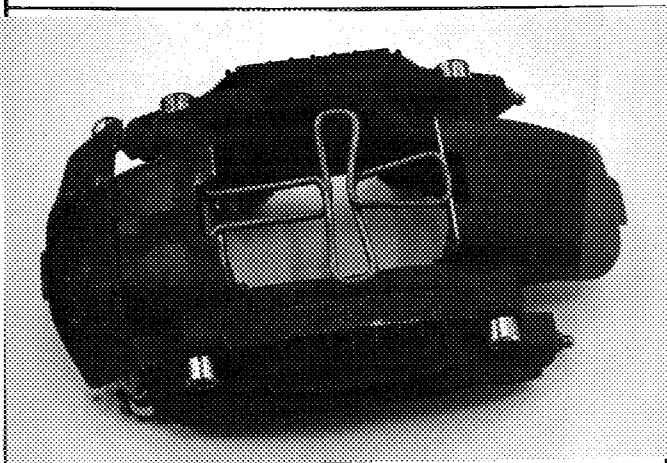
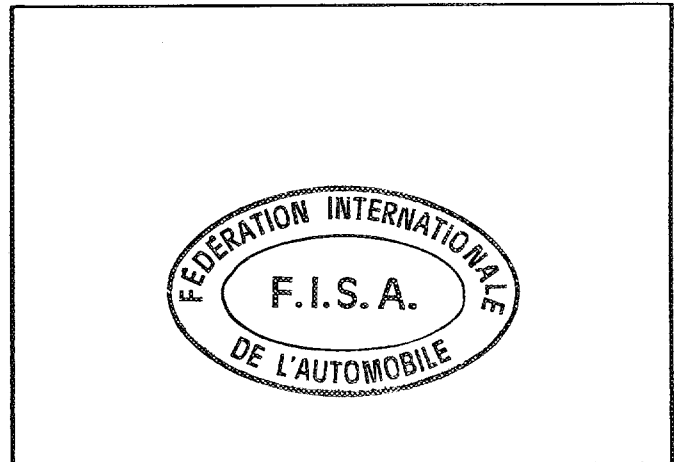
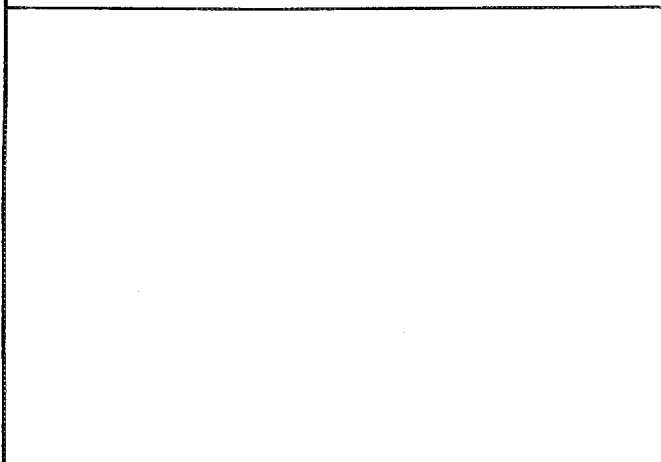
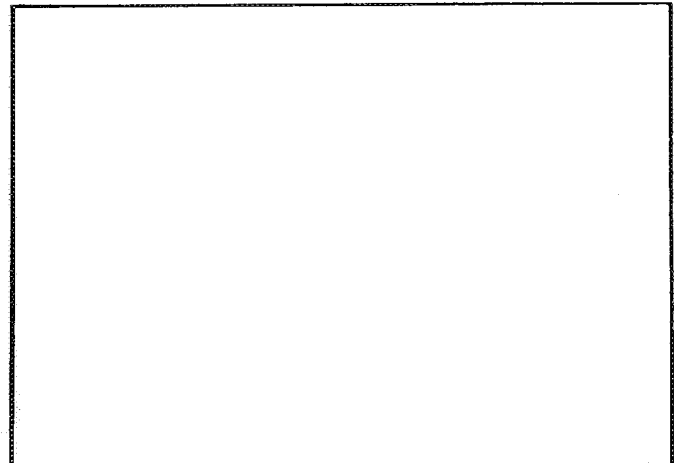
Homologation N°

B - 207

Extension N°

09 / 03 ER

FICHE D'EXTENSION A L'HOMOLOGATION OFFICIELLE FISA  
FORM OF EXTENSION TO THE OFFICIAL FISA HOMOLOGATION

- ES** Evolution sportive du type / Sporting evolution of the type
- ET** Evolution normale du type / Normal evolution of the type
- VF** Variante de fourniture / Supply variant
- VO** Variante option / Option variant
- ER** Errata / Erratum

Homologation valable dès le 01 JAN. 1985 en groupe B  
Homologation valid as from \_\_\_\_\_ in group \_\_\_\_\_

Constructeur Dr. Ing.h.c.f. Porsche AG Modèle et type 911 SC  
Manufacturer \_\_\_\_\_ Model and type \_\_\_\_\_

Page ou ext. Page or ext.	Art. Art.	Description Description
------------------------------	--------------	----------------------------

04 / 03 YU

ARCEAU

limite élastique lire: 34.5 au lieu de: 345  
résistance à la traction lire: 39.0 au lieu de: 390

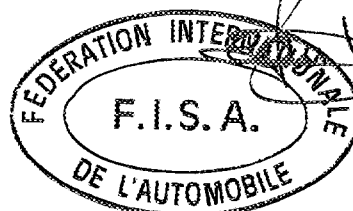

B - 207

10 - 05 VO

Nachtrag zum offiziellen Testblatt der FISA  
Form of extension to the official FISA-Homologation

VO **VO** **Ausstattungsvariante**  
Option variant

Homologation gültig ab 01 MARS 1985 in Gruppe B  
Homologation valid as from in group

Fahrzeughersteller Dr.-Ing.h.c.F. Porsche AG Modell und Typ 911 SC  
Manufacturer of the car Model and type

**Überrollbügel/-käfig**  
Rollbar/rollcage

	Hauptbügel Main rollbar	Diagonalstrebe Longitudinal/diagonal strut	Vorderbügel Front rollbar
Bügelhersteller Rollbar manufacturer	Porsche / Matter		
Material Material	AL ZN M61	AL ZN M61	AL ZN M61
Außendurchmesser Exterior diameter	40 mm	40 mm / mm	40 mm
Wandstärke Wall thickness	3 mm	3 mm / mm	3 mm
Streckgrenze Elastic limit	34,5 kg/mm <sup>2</sup>	34,5 kg/mm <sup>2</sup> / kg/mm <sup>2</sup>	34,5 kg/mm <sup>2</sup>
Zugfestigkeit Tensile strength	39,0 kg/mm <sup>2</sup>	39,0 kg/mm <sup>2</sup> / kg/mm <sup>2</sup>	39,0 kg/mm <sup>2</sup>
Gesamtgewicht inkl. Befestigungsvorrichtungen Total weight including fixings	12 kg		

Kompletter Überrollbügel/-käfig ausgebaut  
Complete rollbar/rollcage outside the car

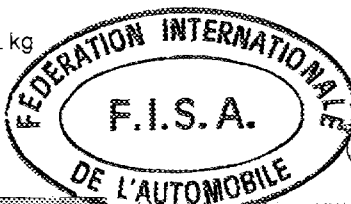
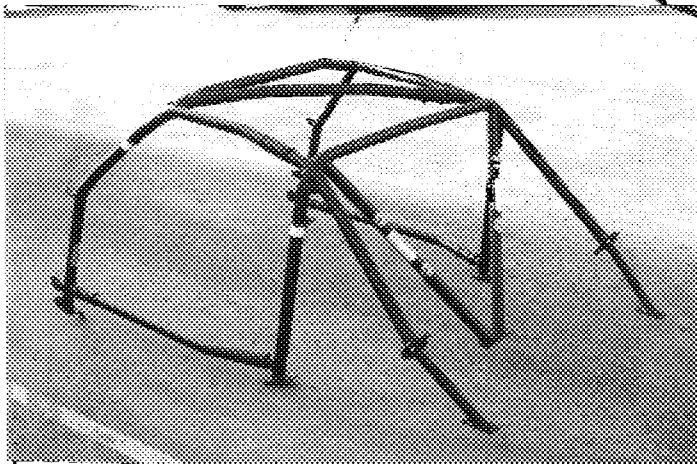

Hiermit wird bestätigt, daß der beschriebene Überrollbügel/-käfig den Anforderungen des Anhangs J der FISA entspricht, insbesondere in Bezug auf seine Befestigungen, Verbindungen und Beanspruchungswerte.

We certify that the present rollbar/rollcage complies with the conditions of the FIA Appendix J, in particular with regard to its attachments, its connections and its stress resistances.

Unterschrift des Fahrzeugherstellers  
Signature of the car manufacturer representative

**Dr. Ing. h.c.F. Porsche**  
Aktiengesellschaft  
7000 Stuttgart 40  
Porschestraße 42 - Postfach 400640  
Telefon 0711/82031

Marque  
Make

Porsche

Modèle  
Model

911 SC

No Homol.

B - 207

PHOTOS OU DESSINS DES FIXATIONS SUR LA COQUE:  
PHOTOS OR DRAWINGS OF THE ATTACHMENTS ON THE BODY:

10-05 VO

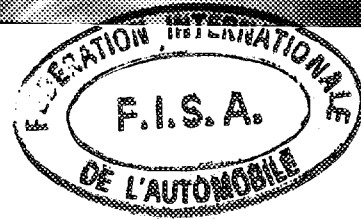
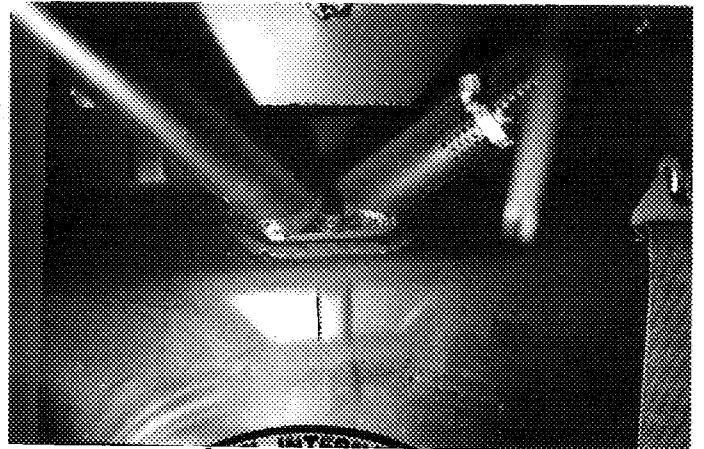
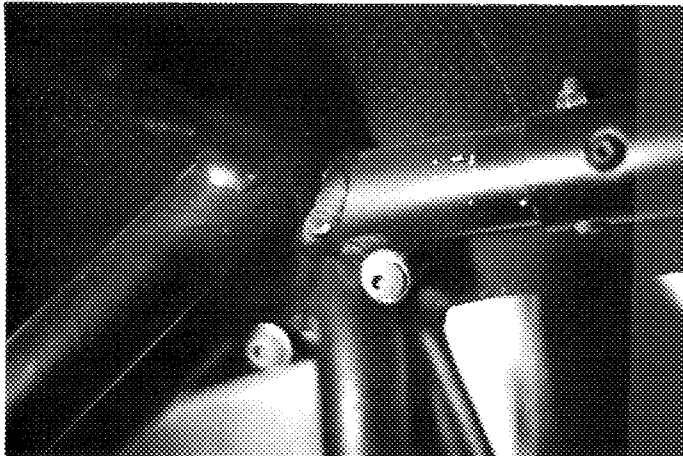
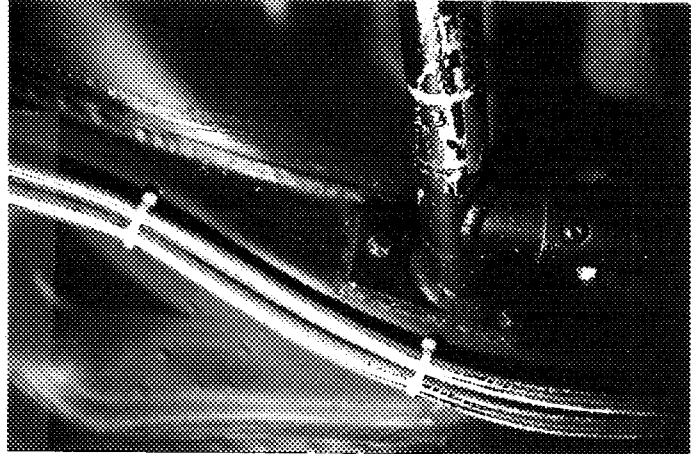
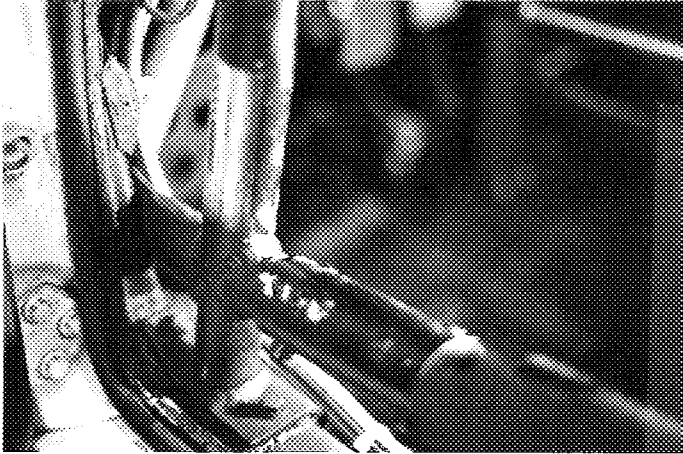

# FÉDÉRATION INTERNATIONALE DU SPORT AUTOMOBILE

ONS Oberste Nationale Sportkommission für den Automobilsport in Deutschland GmbH

Homologation Nr.

B 207

Nachtrag Nr.  
Extension Nr.

11-06 VO

## Nachtrag zum offiziellen Testblatt der FISA

Form of extension to the official FISA-Homologation

- ET** Normale Weiterentwicklung des Typs: ab Fahrgestell-Nr.: \_\_\_\_\_  
Normal evolution of the type: as from chassis number
- ES** Sportevolution  
Sporting evolution
- VF** Liefervariante  
Supply variant
- VO** Ausstattungsvariante  
Option variant
- ER** Berichtigung  
Erratum

01 AVR. 1985

Homologation gültig ab: \_\_\_\_\_ in Gruppe: B  
Homologation valid as from: in group

Hersteller: Dr.-Ing.h.c.F. Porsche AG Modell und Typ: 911 SC  
Manufacturer Model and type

Seite od. Nachtrag <small>Page or ext.</small>	Artikel <small>Art.</small>	Beschreibung <small>Description</small>
7	605	Achsantrieb / Final drive
	b	9/36 9/38 8/37 7/33 8/41
	c	4,000 4,222 4,625 4,7142 5,125

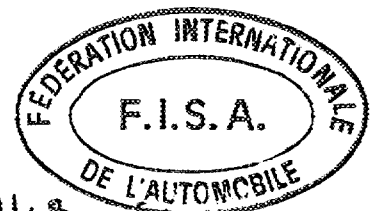

*[Handwritten signature]*



PORSCHE - 911 SC

MARQUE ET MODELE

3/82 -

VALIDITE HOMOLOGATION

B 207

FICHE NR.

B / 3000

GROUPE / CLASSE

EXTENSIONS	DEBUT VALIDITE	DESCRIPTION	NOTES
01/01 ET 02/01 VO	3/82 3/82	MOTEUR 2994cc - RAPPORTS - COUPLE FINAL SUSPENSION - RESERVOIR - FREIN BARRE ANTI ROULIS - POMPE A HUILE DE LA BOITE - RESERVOIR D'HUILE - TRANSMISSION	
03/02 VO	3/82	CARROSSERIE	
04/03 VO	3/82	ARCEAU ALU	
05/01 ER	1/84	ARBRE A CAMES ET SON CARTER	
06/02 ET	1/84	VE AV/AR - DIMENSION - INJECTION LEVEE DES SOUPAPES - SOUPAPES - RAPPORTS - COUPLE FINAL - JANTE	
07/02 ER	9/84	FREIN - CARROSSERIE - ADMISSION CONNECTEUR D'ECHAPPEMENT	
08/04 VO	11/84	SUSPENSION - FREIN - DIRECTION	
09/03 ER	1/85	ARCEAU	
10/05 VO	3/85	ARCEAU ALU	
11/06 VO	4/85	COUPLE FINAL	

Autres homologations du modèle

3062 - 3062 TRANSFERT 3

Vérifiée le 24/3/95 par [Signature] visée ce jour le \_\_\_\_\_ par \_\_\_\_\_